

LASER SENSOR

Laser-Position-Transducer

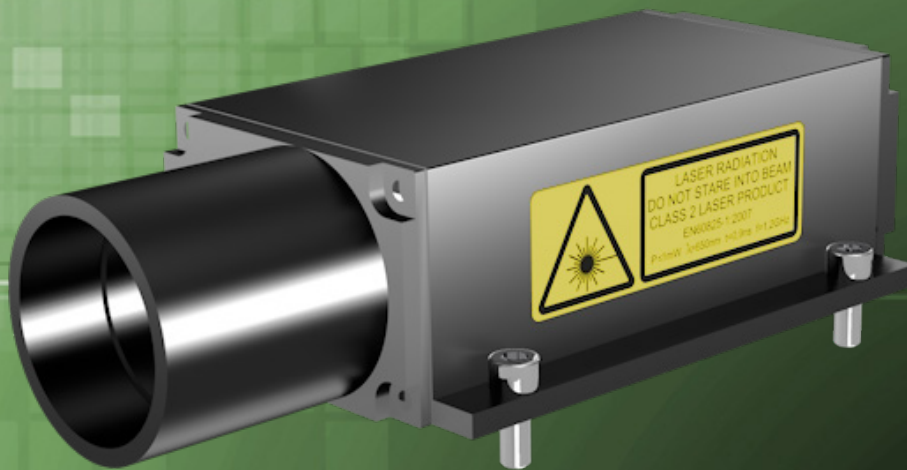

Series LLD-150

Key-Features:

- Measurement range from 0.2 up to 150 m
- Resolution up to 0.1 mm
- Repeatability: ± 0.5 mm
- Linearity up to ± 2 mm
- Protection class IP65
- Operating temperature: -10 to +50 °C, optional -40 to +50 °C
- Measurement frequency up to 50 Hz
- Analog output: 4...20 mA
- Digital output: RS232, RS422, Profibus

Content:

Technical Data2
Technical Drawing2
Getting Started3
Types Of Output3
Factory Setting3
General Safety3
Order Code4
Accessories4

TECHNICAL DATA

Measurement range	[m]	0.2...30 (on natural surfaces) / 0.2...150 (on reflecting foil)			
Linearity	[mm]	±2 (on white surfaces, +15...+30 °C) / ±3 (on natural surfaces, +15...+30 °C) / ±5 (-10...+50 °C)			
Resolution max.	[mm]	0.1			
Repeatability	[mm]	≤0.5			
Measurement frequency	[Hz]	10 (DT-Mode)	50 (DX-Mode)	10 (DT-Mode)	50 (DX-Mode)
Measuring rate	[s]	0.16...6	0.02	0.16...6	0.02
Light source		Laser diode, red			
Wavelength	[nm]	650			
Divergence	[mrad]	0.6			
Laser class		class 2, EN 60825-1:2014			
Analog output		4...20 mA (12 bit, load ≤500 Ω, parametrise using RS232/RS422)		-	
Digital output		RS232, RS422		Profibus	
Transmission rate		2.4 / 4.8 / 9.6 / 19.2 / 38.4 kBaud		max. 12 MBaud (Autodetect)	
Switching output (max. load 0.5 A)		1		2	
Trigger input (not with option H)		trigger impulse 3...24 V		trigger impulse 3...20 V	
Power supply	[VDC]	10...30			
Power consumption max.	[W]	3.2 (with option heating: 25.7)			
Connection		connector M16, 12 pins		2 x connector M12, 5 pins + 2 x connector M12, 4 pins	
Protection class		IP65			
Operating temperature	[°C]	-10...+50 (optional with heating -40...+50)			
Storage temperature	[°C]	-40...+70			
Humidity		10...90 %, not-condensing			
Shock / Vibration		DIN ISO 9022-3			
Electromagnetic compatibility (EMC)		EN 61326-1			
Weight	[g]	760		850	

TECHNICAL DRAWING

LLD-150-RS232, LLD-150-RS422

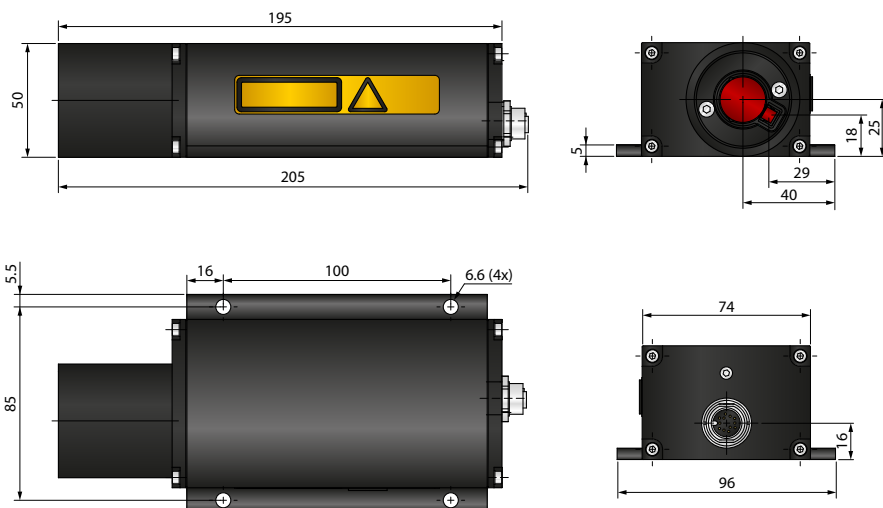
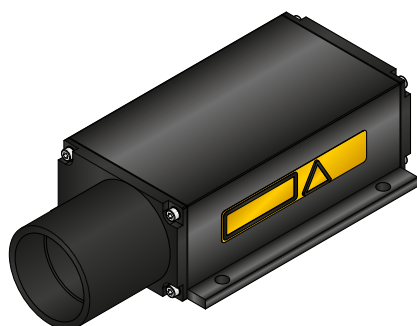

LLD-150-PROF2

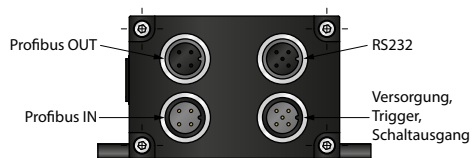

GETTING STARTED

For initial operation, the sensor has to be set into operation mode, i.e. the autostart function must be configured. This function decides on the mode generally to be activated after switching on. Single point and continuous measurement (distance tracking) in different modes are available. Before using the analog output, the measurement range must be scaled: 4 mA is assigned to the minimum, 20 mA to the maximum measurement range.

TYPES OF OUTPUT

Analog output 4...20 mA

The analog output allows for transmission of the results by an analog 4...20 mA signal. The current of the line is proportional to the detected distance.

The measurement range must be scaled during initial operation.

RS232 output

This classical low-price interface for short distances between sensor and PC/control-system/display is ideally suited to laboratory and PC applications.

Data rate 38.4 kBaud max.

RS422 output

Differential interface with RS232 protocol, i.e. the data is transmitted by RS232, just that RXD and TXD are transmitted differential on RS422 basis. Optimized for environment with background noise and long lines (up to 100 m).

Since standard PC's generally do not offer an RS422 interface, this type of communication requires an RS422 interface card or a converter RS422-to-RS232.

Data rate 38.4 kBaud max.

Profibus output

Plug-and-play interface for fieldbus applications.

Configuration by Profibus firmware data file (gsd file), available at www.waycon.de.

Data rate 12 Mbaud max

Digital switching output

This output allows for supervision of the targets, e.g. with respect to the excess of preset thresholds. A corresponding measurement window must be parametrized beforehand, which determines the beginning and the end of the monitored range. The desired switching point can be set inside this range. The details are discussed in a separate manual included in the delivery.

Trigger input (not for models with heating)

A distance measurement can also externally be initiated by a signal (voltage pulse 3...24 V), transmitted via trigger input. The user has to configure the desired delay as well as the pulse edge for triggering. All details are described in the manual included in the delivery.

FACTORY SETTING

As described above the LLD-Sensor has to be switched into the operational mode, before measurements can be made. WayCon offers the possibility for the RS232- and RS422-based laser sensors to make a pre-configuration. In this case the desired measurement range is required, e.g. 5 m measurement range begin, 25 m measurement range end. After this configuration by WayCon 4 mA will be the output at the measurement range begin and 20 mA at the measurement range end. The laser sensor can then be used right after unpacking, without any additional adjustments.

GENERAL SAFETY

- Attention radiation laser!
- Do not stare into beam!
- Do not point the laser beam towards someone's eye!
- It is recommended to stop the beam by a matte object or matte metal shield.
- Laser regulations require the power to the sensor be switched off when turning off the whole system this sensor is part off.

ORDER CODE

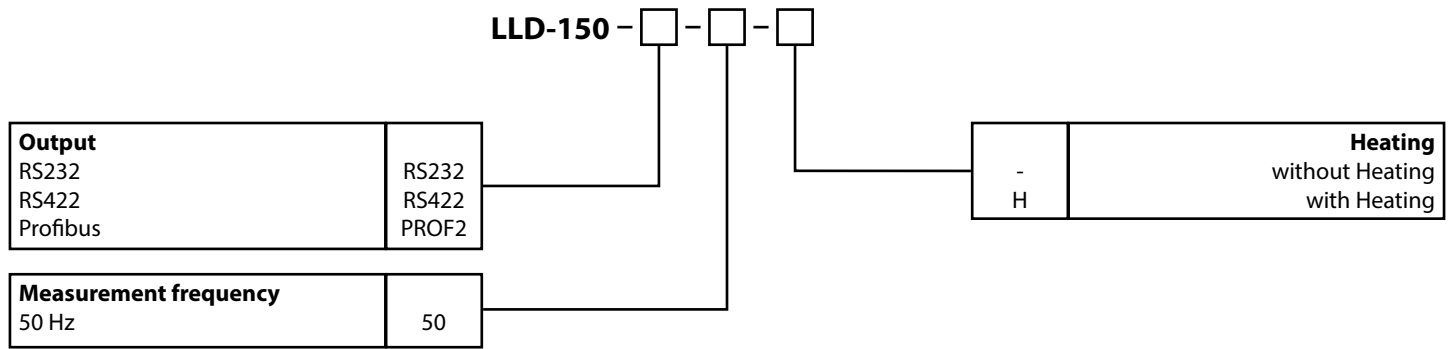

GENERAL ACCESSORIES

ZT51_WEISS	Target board for measurement ranges >30 m
3M 3279 special	Reflecting foil for measurement ranges >30 m

ACCESSORIES RS232/RS422 VARIANT

KAB-LLD-2M	Interface cable 2 m, female, straight	94477	Mating connector M16, female, straight
KAB-LLD-5M	Interface cable 5 m, female, straight	LLD-Aktivierung	Pre-configuration of RS232/RS422 version
KAB-LLD-10M	Interface cable 10 m, female, straight		

ACCESSORIES PROFIBUS VARIANT

Supply cable		Interface cable Profibus	
K5P2M-S-M12	2 m, 5 poles, connector M12	K5P2M-B-M12-PROF	2 m, 5 poles, connector M12, female, open ends
K5P5M-S-M12	5 m, 5 poles, connector M12	K5P2M-SB-M12-PROF	2 m, 5 poles, connector M12, female, male
		K5P2M-S-M12-PROF	2 m, 5 poles, connector M12, male, open ends
		K5P5M-B-M12-PROF	5 m, 5 poles, connector M12, female, open ends
		K5P5M-SB-M12-PROF	5 m, 5 poles, connector M12, female, male
		K5P5M-S-M12-PROF	5 m, 5 poles, connector M12, male, open ends
		K5P10M-B-M12-PROF	10 m, 5 poles, connector M12, female, open ends
		K5P10M-SB-M12-PROF	10 m, 5 poles, connector M12, female, male
		K5P10M-S-M12-PROF	10 m, 5 poles, connector M12, male, open ends

Interface cable RS232 (Profibus variant only)	
K5P2M-M-M12	2 m, 5 poles, connector M12
K5P5M-M-M12	5 m, 5 poles, connector M12

Additional Accessories Profibus	
D5-G-M12-PROF	Profibus OUT connector, M12, male
S5-G-M12-PROF	Profibus IN connector, M12, female
M12-PROF-AW	Profibus terminating resistance, M12

Subject to change without prior notice.

WayCon Positionsmesstechnik GmbH
 email: info@waycon.de
 internet: www.waycon.biz

WayCon
 Positionsmesstechnik

Head Office
 Mehlerstr. 4
 82024 Taufkirchen
 Tel. +49 (0)89 67 97 13-0
 Fax +49 (0)89 67 97 13-250

Office Köln
 Auf der Pehle 1
 50321 Brühl
 Tel. +49 (0)2232 56 79 44
 Fax +49 (0)2232 56 79 45