

INSTALLATION GUIDE

Laser Displacement Sensor Series LAW

For further information please see the data sheet at www.waycon.biz/products/laser-sensors/

INTRODUCTION

WayCon Positionsmesstechnik GmbH would like to thank you for the trust you have placed in us and our products. This manual will make you familiar with the installation and operation of our laser sensors. Please read this manual carefully before initial operation!

Unpacking and checking:

Lift the device out of the box by grabbing the housing. Please pay attention not to touch the laser window. After unpacking the device, check it for any visible damage as a result of rough handling during the shipment. Check the delivery for completeness. If necessary consult the transportation company, or contact WayCon directly for further assistance.

SAFETY INSTRUCTIONS

- These instructions are an integral part of the product and must be kept on hand for the entire duration of its service life.
- Read the operating instructions carefully before using the product.
- Installation, initial start-up and maintenance of the product may only be carried out by qualified personnel.
- Tampering with or modifying the product is impermissible.
- Protect the product from contamination during initial start-up.
- Not a safety component in accordance with the EU machinery directive.

LED DISPLAY

Designation	Lighting pattern	Function
Power	Green	Operating voltage on
	Out	Operating voltage off
Signal	Green	Signal strength OK, sensor ready to measure
	Green blinking	Weak signal, unreliable measurement results
	Red	No signal, sensor contaminated and/or target outside of range
Link/Act	Yellow	Links available
	Yellow blinking	Communication

FUNCTION DESCRIPTION

LAW High-Performance Distance Sensors work with a high-resolution CMOS line array and determine distance by means of an angular measurement at a sampling rate of up to 30 kHz. The sensor is equipped with integrated electronics and no additional controller is required as a result.

Ascertained distance values are read out as process data via the interface and at the analogue output with 16-bit resolution.

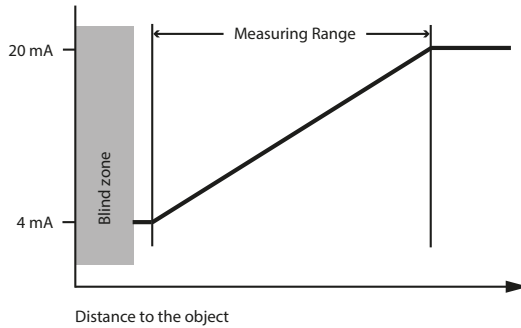

The diffusely reflected light from the measuring point is decisive for the measurement. Inadequate intensity of the remitted light is indicated by an LED signal lamp on the sensor's control panel. In the event of minimal remission, the sensor automatically reduces its sampling and output rates, in order to provide accurate measurement results. Signal strength is indicated on the website as a percentage. Not only does the laser spot produce an illuminated pixel on the CMOS line array, it also generates an intensity curve which is distributed over several pixels. This intensity curve is called the peak, and ideally, it's steep at both ends, monotonically non-decreasing and symmetrical. The curve depends on distance, internal optics and the surface of the object to be measured. The evaluation method is decisive with regard to attainable measuring accuracy. Some surfaces require an evaluation method which is especially suited to them.

Calibration Report

A calibration report is included with the sensor, which graphically represents linearity error as a percentage for the measured value on a matte white surface.

The following is an example of a calibration report:

Calibration Protocol

Order Number: LAW-4
Serial Number: 000001
MAC Address: 00:07:AB:F0:0C:AB

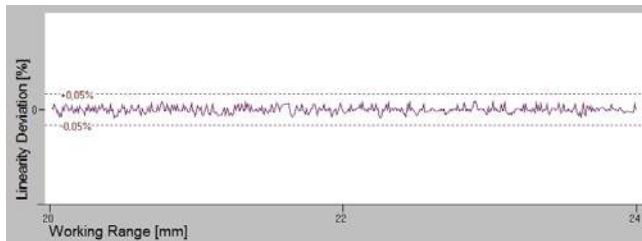

Measurement Conditions:

Measuring Range	4 mm
Working Range	20...24 mm
Measured Surface	White Surface
Evaluation Method	COG
Temperature	20° C (+/-1° C)
Laser Class	2 (max 1 mW)

Differences to the above data can appear due to:

1. Target material and surface
2. Target geometry
3. Sensor mounting
4. Temperature fluctuation during the measurement
5. Strong circulation of warm air between sensor and target

Further statements in the datasheet and the operation instructions are valid.

Inspector: be
Date: 18.08.2020

MEASURING ACCURACY AND ERROR INFLUENCE

Surface Material

Possible objects to be measured include all sorts of materials such as metal, plastic, ceramic, rubber and paper. Suitability for use only needs to be tested individually for highly reflective surfaces and liquids.

Surface Damage on the Object to be Measured

A scratch on the surface of the object to be measured which runs perpendicular to the axis of the lens may cause stronger light emissions, whose maxima are located next to the centre of the spot. An incorrect distance is simulated as a result.

If a moving object is involved, the mean (integral) measured value remains constant when the damaged surface is scanned, i.e. the positive and negative edges cancel each other out due to the damage.

Undesired deflection can be minimized by selecting a suitable average filter.

Extraneous Light

When installing the sensor, it must be assured that no direct or reflected sunlight can shine into the receiver optics. Where difficult applications are involved, this "extraneous light" may interfere with measured value recording. The measuring point should be correspondingly shaded in such cases.

Changes in Remission

The sensors are equipped with luminous intensity control which is automatically adjusted to the level of remission from the object to be measured. If remission from the surface changes during measurement, the sensor compensates for any fluctuation. By selecting a fixed sampling rate, measured values remain accurate even if surface remission changes.

Dependence of Measurement on Angle

Measurement is minimally dependent on angle if the sensor is not aligned at a right angle to the object to be measured. Tilting the sensor results in a greater distance to the object. This change in distance can be set to zero by means of a corresponding offset shift.

The following peak evaluation methods (algorithms) are available:

Centre of Gravity (Cog)

The Cog evaluation method calculates the peak's centre of gravity, whose x-coordinate is the sought crude result. The peak has to be separated from the "sink" for the purpose of centre of gravity analysis, which necessitates calculation of the so-called sink height.

Sink height is the mean value of all pixel intensities and is thus somewhat higher than the background level. All pixels to the left and to the right of the maximum, whose intensity is greater than the sink height, are used in order to calculate the centre of gravity. With 16-bit resolution, the measured values are highly precise thanks to this evaluation method.

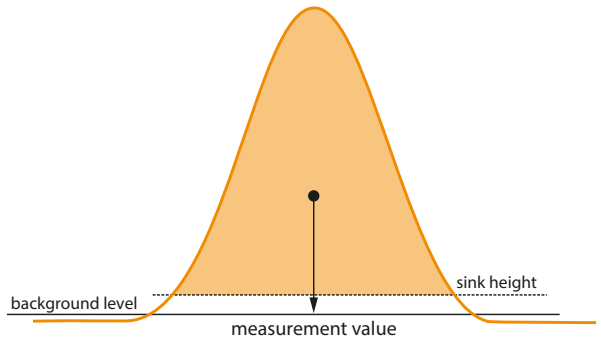

Edge Evaluation

In this evaluation method, the peak's edges are evaluated. The advantage of this evaluation method is the fact that the peak's asymmetrical crests, caused for example by speckle effects resulting from a sheet metal panel, are excluded from the evaluation.

With edge evaluation as well, the measured values achieve highly precise 13-bit resolution.

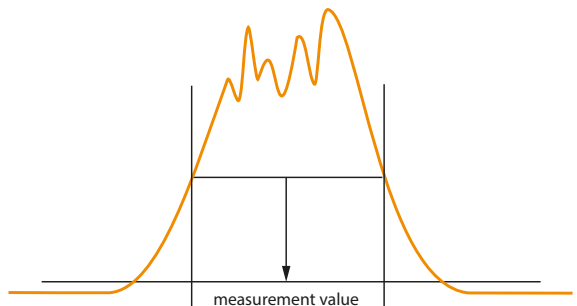

INSTALLATION INSTRUCTIONS

During use of the sensor, applicable electrical and mechanical regulations, standards and safety precautions must be adhered to. The sensor must be protected against mechanical influences.

When installing the sensor, it must be ensured that direct eye contact with the laser beam is avoided. The laser warning must be plainly visible.

When installing the sensor, it must be ensured that the measuring beam is exactly perpendicular to the surface to be measured in order to assure accurate measurement results. Tilting results in a geometrically longer measuring path.

Moving or striped objects

If moving or striped objects will be measured, the sensor head should be mounted with its long side perpendicular to the motion of direction or the stripes. In this way, better measurement results can be achieved in the corners because shadowing is avoided:

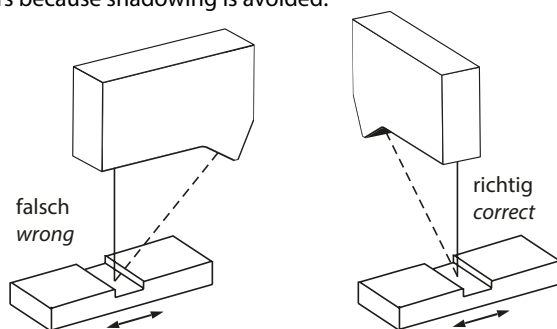

INITIAL START-UP

Two connector plugs are integrated into the sensor's housing. The 8-pin plug supplies the sensor with +24 V operating voltage, whereas communication for parameters configuring and process data is conducted via the 4-pin socket. We recommend the exclusive use of Ethernet switches in order to optimize data communication.

Please note: If Gigabit Ethernet cards are used, the polarity of the Tx and Rx conductors might not be correctly detected. Connecting sensors directly may result in complications. With an Ethernet crossover cable (crosslink), the sensor functions flawlessly via a PC network card. As an alternative, a commercially available 100 Mbit Ethernet switch can also be used.

ELECTRICAL CONNECTION

Connector M12, 8 pins, male

Function	Sensor connector	Connection cable K8P
+V	Pin 1	WH
Input/switching output 2	Pin 2	BN
GND	Pin 3	GN
Input/switching output 4	Pin 4	YE
Input/switching output 3	Pin 5	GY
Analog output	Pin 6	PK
GND _{Analog}	Pin 7	BU
Input/switching output 1	Pin 8	RD

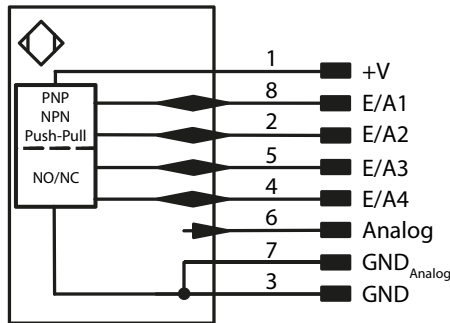
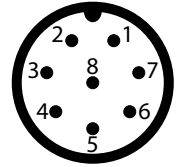

Connector M12, 4 pins, female, d-coded

Function	Sensor connector	Connection cable
Tx+	Pin 1	Pin 1
Rx+	Pin 2	Pin 3
Tx-	Pin 3	Pin 2
Rx-	Pin 4	Pin 6

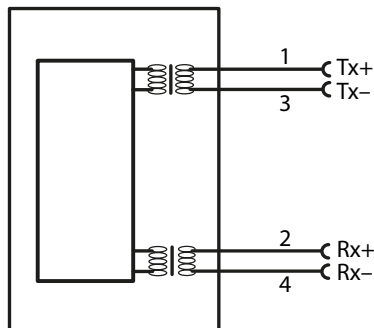
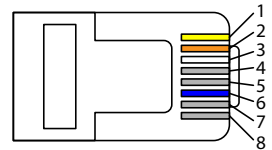
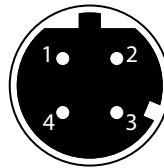

DEFAULT SETTINGS

IP address	192.168.0.225
Subnet mask	255.255.0.0
Evaluation method	COG
Average filter	0 (corresponds to the off state)
Sampling rate	Auto
Output rate	10 kHz
Laser	Auto
Offset	0.0 mm
Analog mode	4...20 mA
E1	Ext. Teach A3
E2	Ext. Teach A4
A3	Switching output PNP / NO
A4	Switching output PNP / NO
Input load: 2 mA	On
Input	Operating voltage active
Teach mode	Foreground Teach-In

SETTINGS

There are several different ways to enter settings to the device:

- Via the integrated website, with which LAW Sensors are equipped. This website functions independent of the operating system and the sensor can be configured via a standard browser. The web-based configuration interface is not required for normal operation with a controller.
- Using the function block for simplified incorporation of LAW Sensors into an S7 controller available for download at www.waycon.biz/downloads.

Attention!

If the sensor is connected to a controller, the settings which have been selected via the website are overwritten by the controller.

Accessing the Website

Start the web browser. Enter the sensor's manually selected IP address (standard: 192.168.0.225) to the address line in your browser and press the enter key. In order to ensure that the browser displays the current settings on the website, the website has to be reloaded whenever changes are made. Otherwise, changes might not be correctly displayed via the website.

Settings are explained below based on the descriptive example provided by the website which is integrated into the sensor.

Device Settings (website)

General Device	Network settings	IP address:	192.168.0.225	Status	Measured value:	107.197 mm
Device settings		Sub net mask:	255.255.0.0	I1:	0	
I/O settings		Standard gateway:	169.254.150.1	I2:	1	
		Password:	****	O3:	0	
			<input type="button" value="Ok"/>	O4:	0	
			Important: After change, rebooting is necessary!	Measurement rate:	4957 Hz	
	Measured value settings	Evaluation method:	COG <input type="button" value="Ok"/>	Signal strength:	94%	
		Average filter (2..1000, 0: Off):	— Values <input type="button" value="Ok"/>	Temperature:	+40°C Old	
		Measurement rate:	5KHz <input type="button" value="Ok"/>	Encoder:	65635	
		Output rate:	5KHz <input type="button" value="Ok"/>			
		Emitted light:	Auto <input type="button" value="Ok"/>			
		Offset:	0.000 mm <input type="button" value="Ok"/>			
	General Settings	Encoder reset:	<input type="button" value="Reset"/>			
		Default values:	<input type="button" value="Reset"/>			

1. Network settings:

The IP address and the addresses for the subnet mask and the gateway can be changed in the respective fields. Changes are activated by entering the "admin" password and by restarting the device. Please make sure that the selected subnet mask is actually available within the network. Otherwise you might not be able to find the sensor in the network.

2. Measured value settings

- **Evaluation method:** functions description
- **Average filter:** Adjustable, rolling average filter from 1 to 1000 measured values.
 - The smaller the selected value, the faster the measured value reacts to jumps.
 - The larger the selected value, the more smoothed the measured value becomes.
- **Sampling rate:** Possible settings include "Auto" (the sampling rate is adjusted automatically) or "=output rate" (sampling rate = output rate). Values can be selected within a range of 900 to 30,000 Hz as well.
- **Output rate:** Values can be selected within a range of 10 to 30,000 Hz. The measured values are compiled individually as an Ethernet data packet at the selected rate. Example: Using the "extended continuous measurement" evaluation method with 150 distance values and a selected output rate of 1 kHz (corresponds to 1 ms), you get the entire data packet every 150 ms.
- **Laser:** Laser power adjustable from 0.1 to 1 mW, or automatic
- **Offset:** If desired, a zero-point offset can be entered here.
- **Screening Grid:** When activated, the effects of the screening grid on the measured distance value and linearity are compensated for by this option.

3. General settings

- **Encoder reset:** Resets the encoder input to zero.
- **Default values:** Resets all values to their default settings.

Exception: network settings

I/O Settings (website)

1. Analog output:

Selection of 0 to 10 V or 4 to 20 mA.

2. I/O settings:

Various pin functions can be selected for the individual inputs/outputs.

Depending on the selected setting, context menus offer corresponding selection options.

Pin function:

- **Switching output:** The selected output functions as a switching output.
- **External teach-in:** One of the sensor's switching inputs can be taught in anew by applying an electrical signal to this input.
- **Encoder E1+E2:** A 2-channel rotary encoder with HTL square-wave signal must be used. Channel A is displaced 90° relative to channel B. It must be assured that a shielded cable is used in order to avoid possible interference or crosstalk between the conductors.

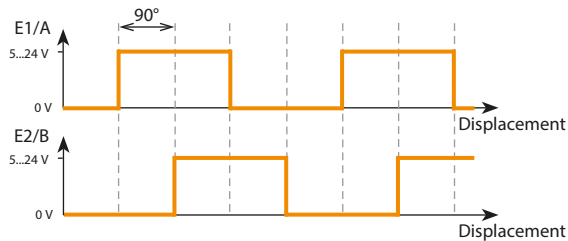

- **Encoder reset:** The encoder is reset to "0".
- **Laser off:** The laser can be switched on or off by activating the input load or the input voltage.

Output:

- **PNP output:** The load or the analysis module is connected between the minus pole (reference) and the output. When switched, the output is connected to the plus pole via an electronic switch. A PNP output can also be equipped with a pull-down resistor.
- **NPN output:** The load or the analysis module is connected between the plus pole (reference) and the output. When the sensor is switched, the output is connected to the minus pole via an electronic switch. An NPN output can also be equipped with a pull-up resistor.
- **Push-pull:** alternate PNP and NPN switching

Output function:

- The output can be configured as NO (normally open) or NC (normally closed).

Teach-In mode:

- Teach-In:** a function by means of which the sensor is caused to automatically calculate and save future settings based upon momentarily acquired values by pressing a button or applying a control signal.
- FT teach-in mode (window teach-in):** There are two switching points in the case of window teach-in. The distance between the two switching points is called the window. The size of the window is designated window width. The sensor is switched when an object is within the window.

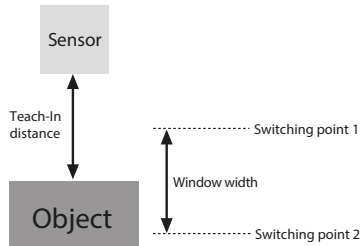

- VT teach-in mode (foreground teach-in):** Teach-in is performed while the sensor is aligned to the object. The switching distance is then automatically set to a distance which is slightly greater than the clearance between the sensor and the object. The sensor is thus switched for all objects whose distance to the sensor is equal to or less than the distance to the object used for the teach-in procedure.

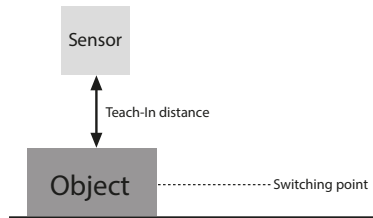

- Change switching point:** Shifts the switching point to the entered distance. In the case of foreground teach-in this is the teach-in distance described above, and in the case of window teach-in it's the distance to the middle of the window.
- Hysteresis:** Describes the distance between the switch-on and switch-off points. Due to the highly stable measured values provided by this range of sensors, hysteresis can be set very low – even down to 0.000 mm. This setting may be advisable in certain applications where an average filter is used.
- Switching reserve:** Clearance between the teach-in distance and the sensor's switching point. Switching reserve ensures reliable object detection even in the case of slightly fluctuating distances between the objects and the sensor.
- Window size:** see window "teach-in".

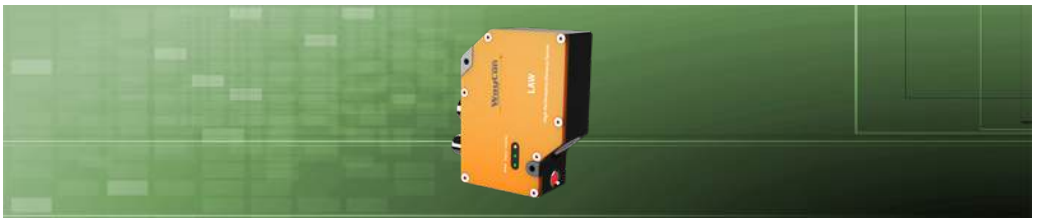

SETTINGS

2 mA input load:

- Input load is set to 2 mA as a default value, but it can be switched off in the dropdown menu (e.g. if the PLC has a high-impedance PNP output).

Input setting:

- **Operating voltage active:** Pending tasks are executed when input voltage is on.
- **Operating voltage inactive:** Pending tasks are executed when input voltage is off.

MAINTENANCE

- This sensor is maintenance-free.
- It is advisable to clean the lens and the display, and to check the plug connections at regular intervals.
- Do not clean with solvents or cleansers which could damage the product.

DISPOSAL

Please always dispose of defective or irreparable appliances in an environmentally friendly manner and in accordance with the applicable legal provisions and disposal regulations. If required, we will be happy to assist you with environmentally friendly disposal.

Caution: Incorrect disposal can cause environmental damage!

Certain components such as electrical waste, electronic components, lubricants and other auxiliary materials must be disposed of as hazardous waste.

Please note that hazardous materials may only be disposed of by authorized specialist companies.

Dismantled components should be disposed of as follows:

- Metal components with scrap metal
- Electronic components with electronic waste
- Plastic parts at the recycling centre
- Other components must be sorted and disposed of according to their material properties