

LASER DISPLACEMENT SENSOR

Links to further documents for this series:

[Installation guide](#)

[Teaching guide](#)



LAS-T SERIES

Key-Features:

- Measurement ranges from 40 to 800 mm
- Linearity up to $\pm 12 \mu\text{m}$
- Resolution up to $4 \mu\text{m}$
- Analog output 4...20 mA or 0...10 V
- Point and line laser versions
- Protection class: IP67
- Operating temperature: 0 to 50 °C
- Individual parametrization by teach-in procedure
- Very precise distance measurement on most materials
- Protected against reverse polarity and short circuit

Content

Technical Data	2
Technical Drawing	3
Teach-In - Diagrams.....	3
Order Code.....	5
Accessories.....	5

TECHNICAL DATA

		LAS-T5-40	LAS-T5-100	LAS-T5-250	LAS-T5-500	LAS-T-800
Measurement range	[mm]	30...70	30...130	50...300	100...600	200...1000
Linearity ¹⁾	[mm]	±0.012...±0.06	±0.015...±0.2	±0.03...±1	±0.05...±2	±0.11...±1.65
Resolution ¹⁾	[mm]	0.004...0.02	0.005...0.06	0.01...0.33	0.015...0.67	0.02...0.4
Minimal teach-in range	[mm]	>2	>3	>5	>10	
Light source		laser diode red, pulsed				
Laser class		2				
Beam type		point				point or line ²⁾
Beam diameter point laser	[mm]	1...0.2	2...1	2		
Beam height line laser	[mm]	-				6...20
Beam width line laser	[mm]	-				2.5
Wavelength	[nm]	650				
Sensor element		photo diode array				
Measurement frequency	[kHz]	1				0.25
Response time	[ms]	<0.9				<4
Output signal		4...20 mA or 0...10 V				4...20 mA and 0...10 V
Alarm output		-				PNP ³⁾
Power-On indicator		LED green				
Alarm indicator		LED red				
Staining indicator		LED red flashing				
Supply	[VDC]	12...28				
Current consumption max.	[mA]	100				
Load resistance	[kΩ]	with output signal 4...20 mA: <0.3 with output signal 0...10 V: >100				
Inverse-polarity protection		yes				
Short-circuit		yes				
Protection class		IP67				
Working temperature	[°C]	0...50				
Connection (180° turnable)		M12 connector, 5 pins				M12 connector, 8 pins
Housing		zinc die-casting				aluminium

¹⁾ Values for linearity and resolution are given for a mat white reference surface.

²⁾ The detector calculates an optical (not a mathematical) averaging of the sampled surface, i.e. a kind of a surface integral.

³⁾ Binary open collector switching output with PNP transistor switching to +Vs. Consequently the load current flows from the switching output through the load resistance to 0 V. A suppressor diode is integrated and also an internal load resistor of approx. 10...50 kΩ for measurement purposes.

TECHNICAL DRAWING

LAS-T5

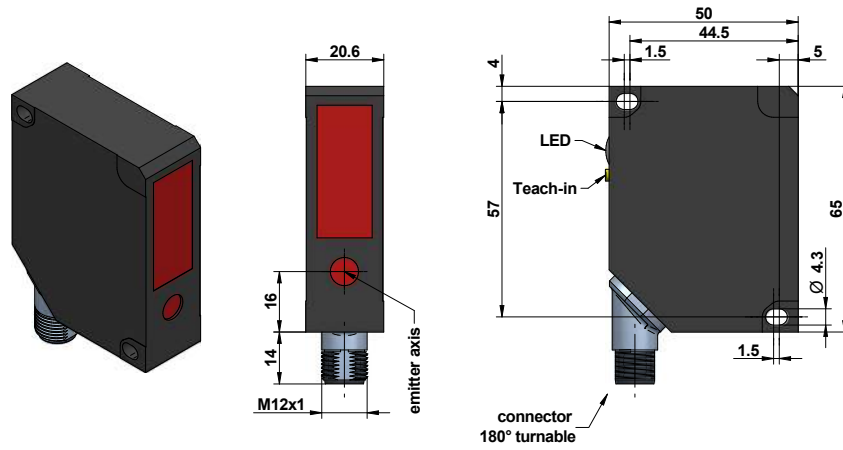

LAS-T

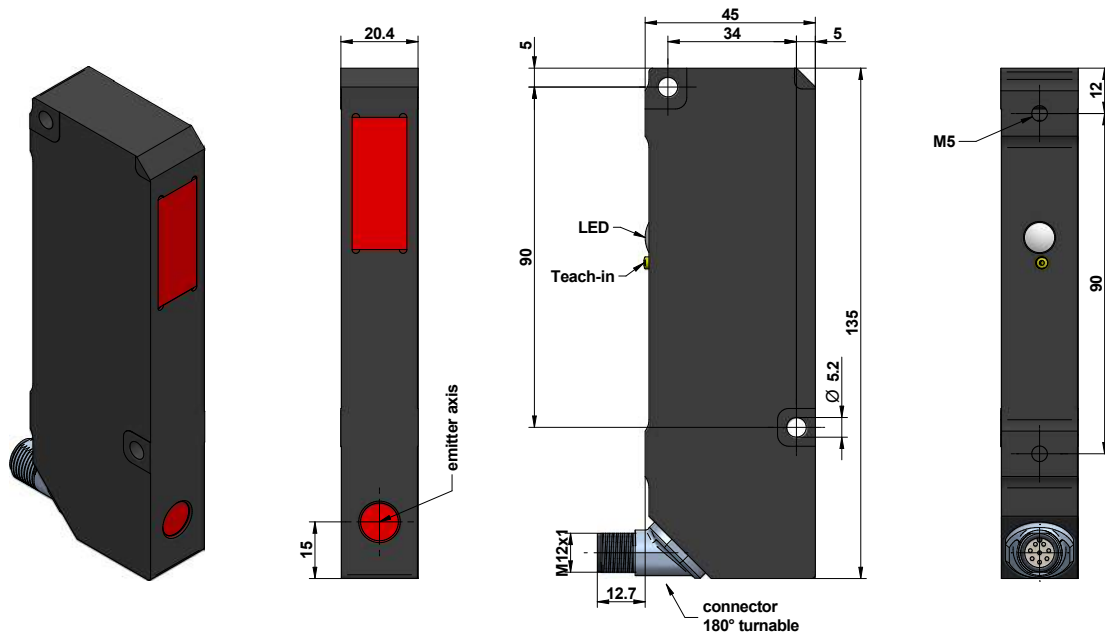

TEACH-IN - DIAGRAMS LINEARITY AND RESOLUTION

The following diagrams show the change of the linearity and resolution depending on the teached measurement range. The shorter the teached measurement range, the better the linearity and resolution. MR stands for the teached measurement range.

LAS-T5-40

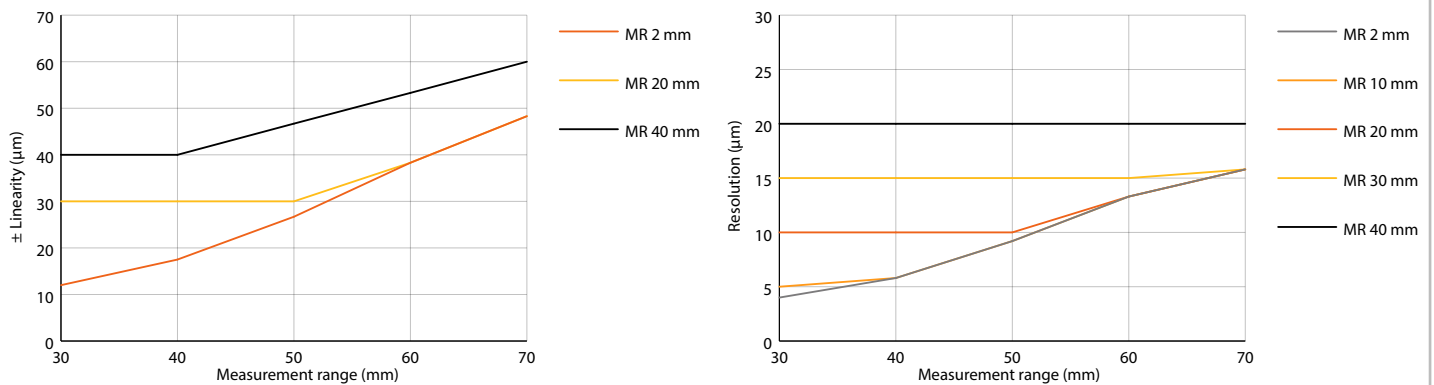

TEACH-IN - DIAGRAMS LINEARITY AND RESOLUTION

LAS-T5-100

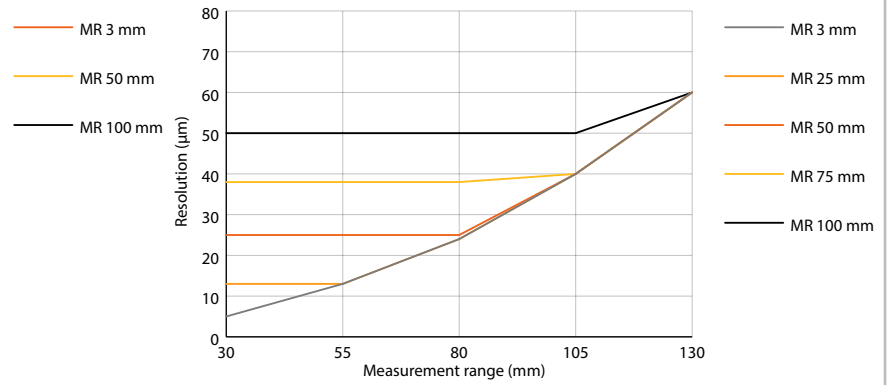
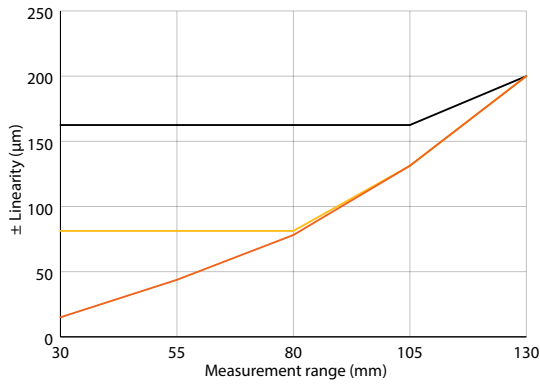

LAS-T5-250

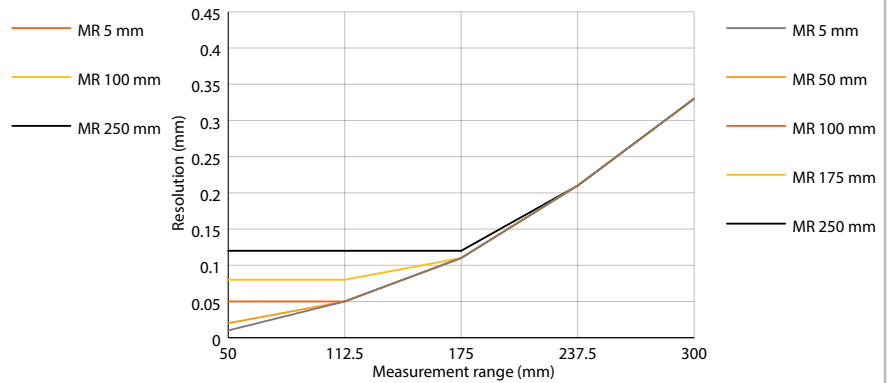
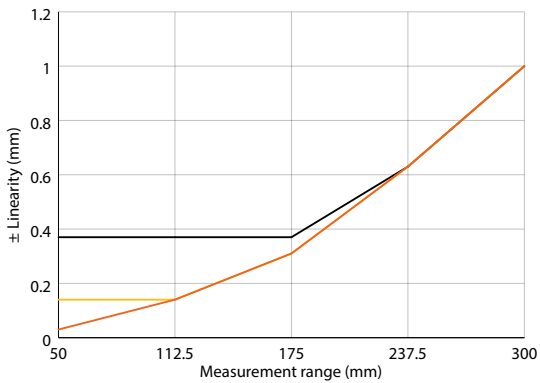

LAS-T5-500

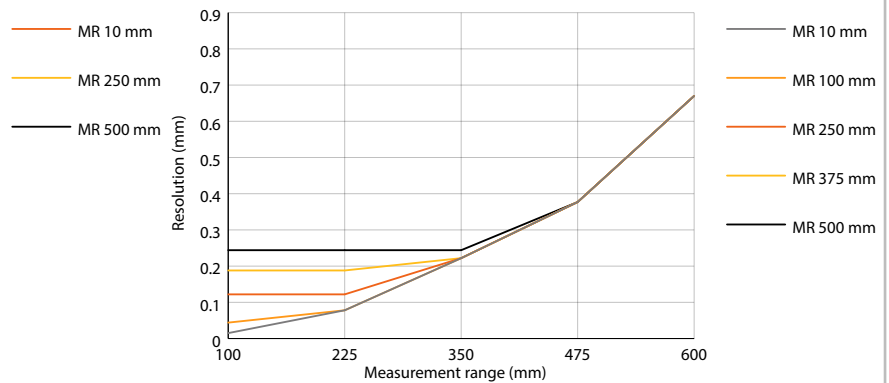
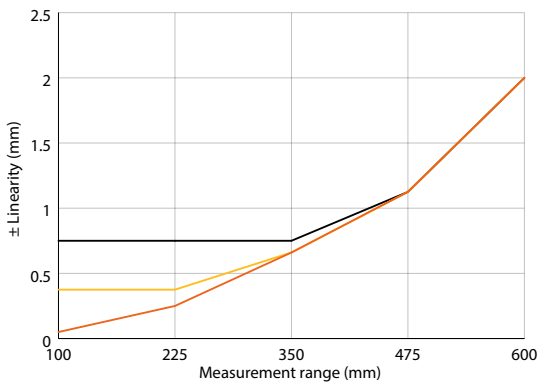

LAS-T-800

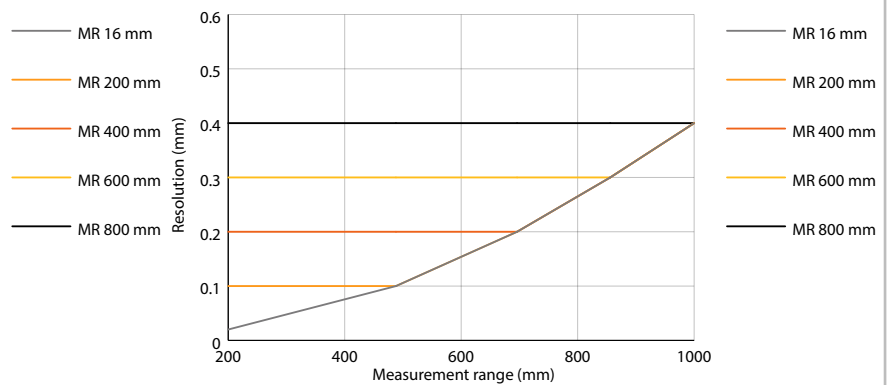
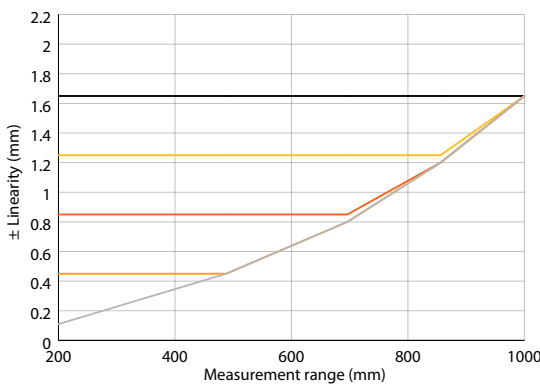

ORDER CODE

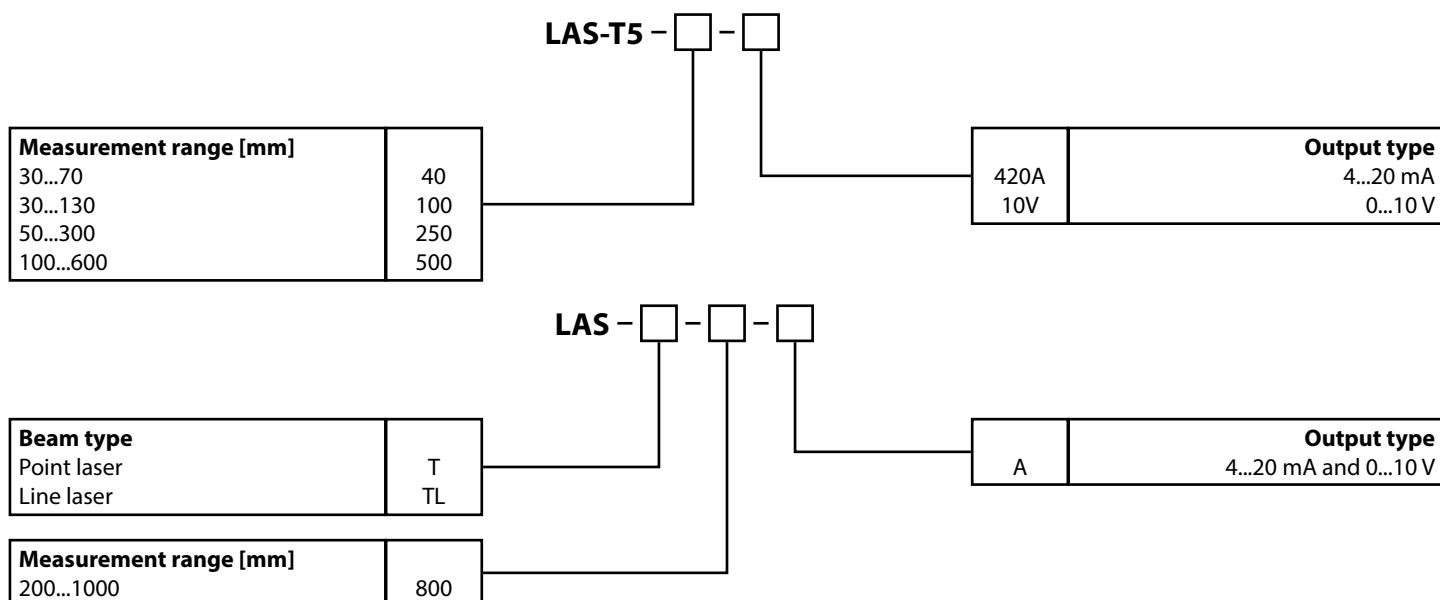

ACCESSORIES

Cable for LAS-T5 with mating connector M12, 5 poles, shielded

K5P2M-S-M12	2 m, connector straight
K5P5M-S-M12	5 m, connector straight
K5P10M-S-M12	10 m, connector straight
K5P2M-SW-M12	2 m, connector angular
K5P5M-SW-M12	5 m, connector angular
K5P10M-SW-M12	10 m, connector angular

Protection glass for LAS-T5

Schutzglas-LAS	self-adhesive
----------------	---------------

Cable for LAS-T with mating connector M12, 8 poles, shielded

K8P2M-S-M12	2 m, connector straight
K8P5M-S-M12	5 m, connector straight
K8P10M-S-M12	10 m, connector straight
K8P2M-SW-M12	2 m, connector angular
K8P5M-SW-M12	5 m, connector angular
K8P10M-SW-M12	10 m, connector angular

Digital displays for sensors with analog output, 2 channel

WAY-AX-S	touch screen, supply: 18...30 VDC
WAY-AX-AC	touch screen, supply: 115...230 VAC

For more information and options please refer to the [WAY-AX data sheet](#).

GENERAL SAFETY INSTRUCTIONS

- Attention radiation laser.
- Do not stare into beam.
- Do not point the laser beam towards someone's eye.
- It is recommended to stop the beam by a matte object or matte metal shield.
- Laser regulations require the power to the sensor be switched off when turning off the whole system this sensor is part of.

Subject to change without prior notice.

WayCon Positionsmesstechnik GmbH

Email: info@waycon.de

Internet: www.waycon.biz

WayCon

Positionsmesstechnik

Headquarters Munich

Siemensstr. 5

85521 Ottobrunn

Tel. +49 (0)89 67 97 13-0

Office Cologne

Auf der Pehle 1

50321 Brühl

Tel. +49 (0)89 67 97 13-100