



MESSRÄDER

Surface of the measured material	Recommended Profile
Cardboard	1, 2, 3, 4, 5
Wood	1, 2, 3, 4, 5
Textile	1, 2, 3, 4
Plastics (e.g. PVC, PE,...)	2, 3, 4, 5
Paper	2, 3, 4, 5
Wire, greased metals, steel profiles, leather	2
Carpet, cables, nonwoven	3
Greased metals, glass, floor coverings	4
Painted surfaces	2, 4
Rubber, soft plastic	1

Order Code	Profile Measuring Wheel	Coating	Weight
MSR-02-1	1	diamond knurl (aluminium)	60 g
MSR-02-2	2	plastic (polyurethane) smooth	60 g
MSR-02-3	3	tufted rubber (polyurethane)	60 g
MSR-02-4	4	plastic (polyurethane) corrugated	60 g
MSR-05-1	1	diamond knurl (aluminium)	775 g
MSR-05-2	2	plastic (polyurethane) smooth	700 g
MSR-05-3	3	tufted rubber (polyurethane)	700 g
MSR-05-4	4	plastic (polyurethane) corrugated	700 g
MSR-12-5	5	natural rubber (NR) smooth	100 g

NOTE

The measuring wheels can only be used for in-house purposes which are not subject to the stipulations of the German calibration code.

INSTALLATION GUIDE

Encoder Arm, Measuring Wheels

FIRST STEPS

WayCon Positionsmesstechnik GmbH would like to thank you for the trust you have placed in us and our products. This manual will make you familiar with the installation and operation of our spring encoder arm and the measuring wheels. Please read this manual carefully before initial operation!

Unpacking and checking:

Carefully lift the device out of the box by grabbing the housing. After unpacking the device, check it for any visible damage as a result of rough handling during the shipment. Check the delivery for completeness. If necessary consult the transportation company, or contact WayCon directly for further assistance.

MOUNTING

A) Mount holder

Fasten flexible arm to the machine by means of the cross-recess groove in such a way that the mobile arm is parallel to the running direction. Mount encoder on the flexible arm and establish the electric connection in such a way that the arm is not restricted in its travel and not subject to any tensile force.

B) Set the contact pressure

If a measuring wheel is mounted directly on the shaft of a rotary encoder, the pressure force between the measuring wheel and measured material should not exceed the radial shaft load listed in the data sheet of the encoder.

Loosen central screw by using an Allen key and bring arm in approximately the correct position. Engage, for example a screwdriver in the provided bore [1] in the setting wheel E and adjust arm so that the measuring wheel makes contact with the object to be measured. Set the contact pressure by turning the setting wheel E by about one notch (~10...30 N). Re-tighten central screw. Set contact pressure to a value that will not damage the object to be measured.

C) Maintenance

Ensure smooth running for the arm by regular checks. If running becomes sluggish clean the arm/wheel, or send in to WayCon for maintenance.

INSTALLATION GUIDE

Encoder Arm, Measuring Wheels

TECHNICAL DRAWING ENCODER ARM

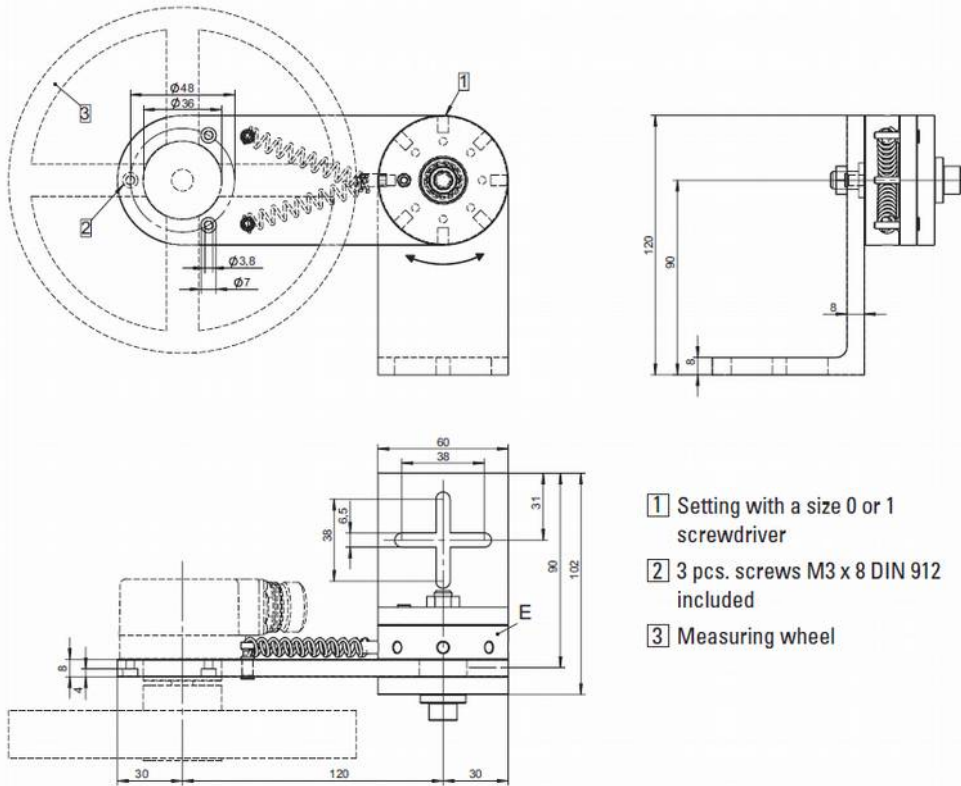

TECHNICAL DRAWING MEASURING WHEEL

Material of wheel body: aluminium
Temperature range: -30...80°C

MSR-02

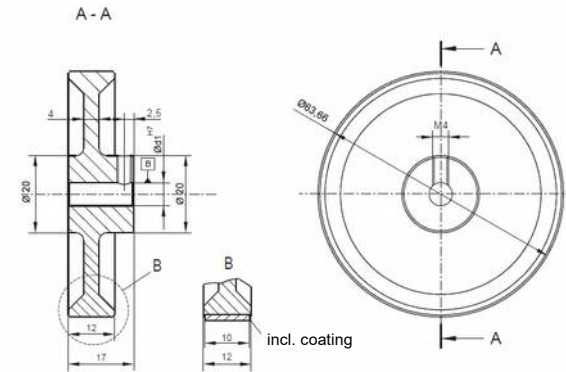

MSR-05

