

INSTALLATION GUIDE

Draw wire sensors series ZX

For further information please see the data sheet at www.waycon.biz/products/draw-wire-sensors/

FIRST STEPS

WayCon Positionsmesstechnik GmbH would like to thank you for the trust you have placed in us and our products. This manual will make you familiar with the installation and operation of our draw wire sensors. Please read this manual carefully before initial operation!

Unpacking and checking:

Carefully lift the device out of the box by grabbing the housing. Do not pull the rope. After unpacking the device, check it for any visible damage as a result of rough handling during the shipment. Check the delivery for completeness.

If necessary consult the transportation company, or contact WayCon directly for further assistance.

MOUNTING OF THE SENSOR

Mount the sensor at the designated place before extracting the rope and before attaching the rope to the measuring target.

The mounting holes in the housing allow mounting with two 2 mm screws. Alternatively, the unit may be mounted with two 4-40 screws that thread directly into the housing.

After mounting the ZX sensor in its place, carefully tear the wire rope out of the sensor (do not let the wire rope snap back!) and attach it to the target.

Eye fitting version: The eyelet at the end of the wire rope can be pulled onto a hook or be fixed to the target using a screw. Do not bend the wire rope leaving the eyelet.

Leader wire rope version: Fix the leader wire to the clip using the crimp ferrules (see bottom page 3). Be careful not to damage the wire while crimping.

HANDLING THE WIRE ROPE

- When installing or operating the sensor, take care not to let the rope snap back by mistake or extract the wire rope over the specified measurement range, as this might destroy the sensor.
- The rope must be extracted from the sensor vertically. The maximum variation from the vertical is 2°. Avoid carefully extracting the rope at an inclination, since the durability of the instrument would shorten considerably. If it is not possible to keep the limit of 2°, a deflection pulley has to be used.
- The measurement range starts after the wire rope is pulled out approx. 1.0 mm.
- Guide the rope preferably in corners or guarded in channels to prevent pollution or accidental touch.
- Avoid guiding the rope over edges or corners. Use a deflection pulley instead.
- Do not operate the sensor if the rope is buckled or damaged. A ripping of the rope may lead to injuries or a damaging of the sensor.

ELECTRICAL CONNECTION

General information ZX-PA

Resistance:	5 k Ω (± 10 %)
Power supply:	max. 30 VDC
Output signal:	24.8 mV/mm at 1 VDC input voltage
Output impedance:	0...5 k Ω

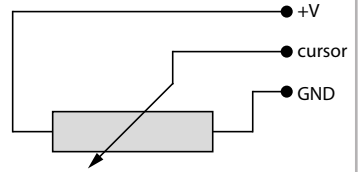

General information ZX-HM

Warm-up time:	5 min
Power supply:	5 VDC ($\pm 0,25$)
Output signal:	89 % \pm 3 % of excitation voltage
Excitation current:	max. 21 mA
Min. load impedance:	min. 30 k Ω

Connection ZX-PA and ZX-HM

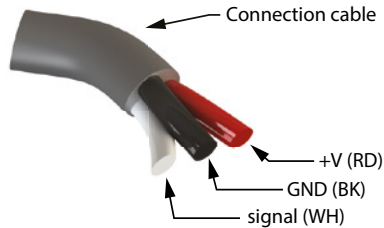

MAGNETIC FIELDS

Model ZX-HM employs a hall effect device which produces an output signal that is proportional to the field strength of an internal magnet. Thus, the presence of an external magnet with field strength of 1 mT or greater measured on the side of the unit opposite the wire rope exit can have a minor effect on the output of the unit. The output may shift by several mV. As long as the magnet is stationary the linearity of the unit will not be affected with magnetic field strengths up to 6 mT. However, if the magnet moves (e.g. a fluctuating external magnetic field), a fluctuation in the electrical output will also be noticed. For best results, model ZX-HM should be used in the absence of external magnets. As a side note, the ZX-HM is not affected by the presence of ferrous material.

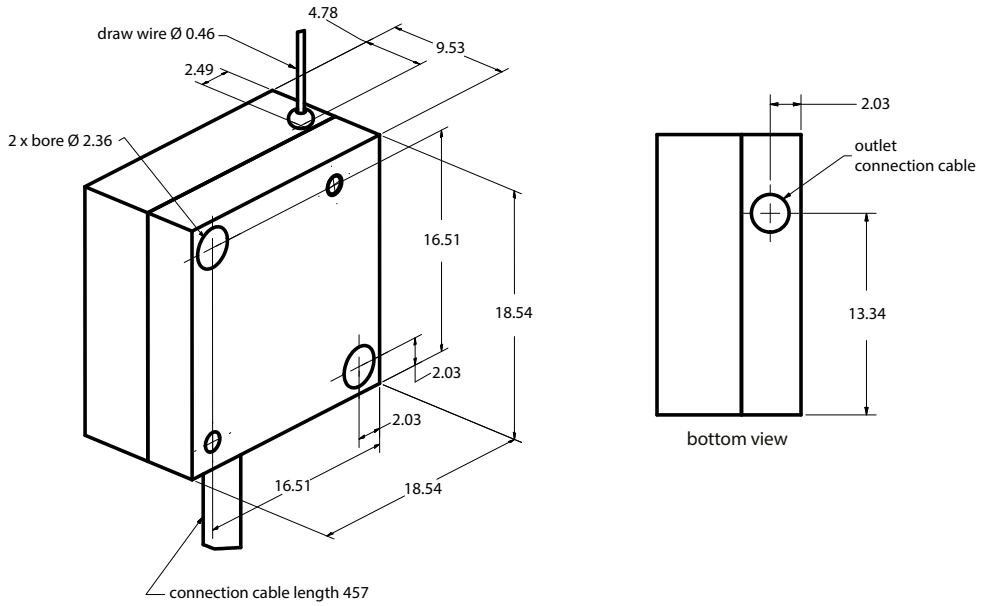

Draw wire attachment

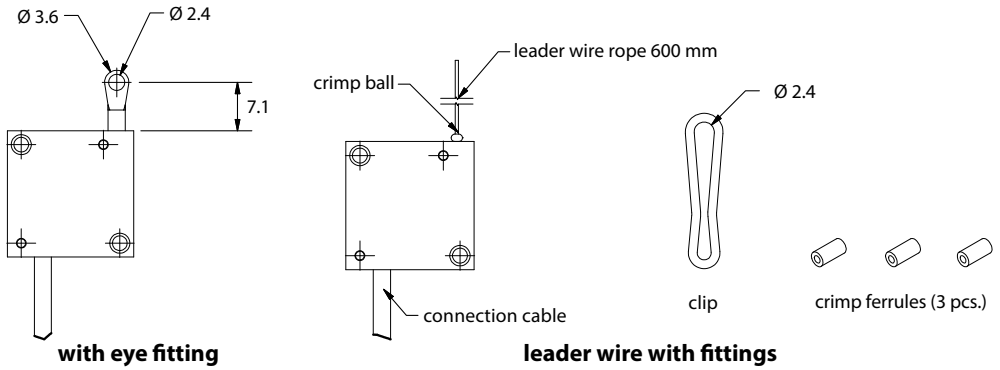



IMPORTANT NOTES

- Don't let the rope snap back. If the rope is retracted freely, this may lead to injuries (whiplash effect) and the device may be damaged. Caution when unhooking and retracting the rope into the sensor.
- The ZX-HM must be installed away from sources of strong magnetic fields, as they may influence the measurement results.
- Do not try to open the device. The stored energy of the spring drive may lead to injuries when being mishandled.
- Do not touch the rope when operating the sensor.
- Avoid guiding the rope over edges or corners. Use a deflection pulley instead.
- Do not operate the sensor if the rope is buckled or damaged. A ripping of the rope may lead to injuries or a damaging of the sensor.

DISPOSAL

Please always dispose of defective or irreparable appliances in an environmentally friendly manner and in accordance with the applicable legal provisions and disposal regulations. If required, we will be happy to assist you with environmentally friendly disposal.

Caution: Incorrect disposal can cause environmental damage!

Certain components such as electrical waste, electronic components, lubricants and other auxiliary materials must be disposed of as hazardous waste.

Please note that hazardous materials may only be disposed of by authorized specialist companies.

Dismantled components should be disposed of as follows:

- Metal components with scrap metal
- Electronic components with electronic waste
- Plastic parts at the recycling centre
- Other components must be sorted and disposed of according to their material properties