

DRAW WIRE SENSOR

Links to further documents for this series:

[Installation guide](#)

[Manual for CANopen](#)

[Data sheet TEDS connector](#)



SX120 SERIES

Key-Features:

- Measurement ranges from 3000 to 5000 mm
- Analog output: potentiometer, voltage, current
- Optional teachable voltage outputs
- Digital Output Incremental: RS422 (TTL), Push-Pull
- Digital Output Absolute: CANopen, SSI, Profibus, EtherCAT, Profinet
- Linearity up to $\pm 0.02\%$ of full scale
- Protection class up to IP67
- Temperature range: $-20...+85\text{ }^{\circ}\text{C}$ (optional $-40\text{ }^{\circ}\text{C}$ or $+120\text{ }^{\circ}\text{C}$)
- High dynamics and interference immunity factor
- Customised versions available
- Optional with TEDS connector

Content

Technical Data Analog	2
Technical Data Incremental	3
Technical Data Digital WCAN.....	4
Technical Data Digital Absolute.....	5
Mechanical Data.....	6
Technical Drawing	6
Options	8
Accessories.....	9
Order Code.....	10

TECHNICAL DATA ANALOG OUTPUT

Measurement range MR ¹⁾	[mm]	3000	4000	5000
Linearity ²⁾	[%]		±0.1	
Improved linearity (optional) ²⁾	[%]		±0.05	
Resolution		see output types below		
Sensor element		Hybrid Potentiometer		
Connection		connector output M12 or cable output axial (TPE cable)		
Protection class		IP65, optional IP67		
Humidity		max. 90 % relative, no condensation		
Temperature		see output types below		
Mechanical data		extraction force, max. velocity and max. acceleration see „Mechanical Data“		
Housing		aluminium, anodised, spring case PA6		
Draw wire		stainless steel V2A Ø 0.5 mm		
Weight	[g]	1300 to 1600, depending on the measurement range		

¹⁾ others on request

²⁾ linearity max. ±0.15 % in combination with outputs 5R and 10R

ELECTRICAL DATA ANALOG OUTPUT

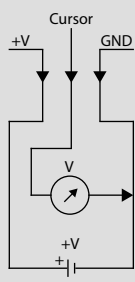
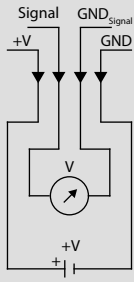
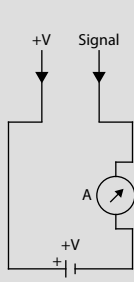
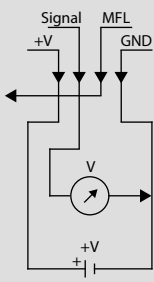
Output type	Potentiometer			Voltage ¹⁾				Current	Voltage (teachable)		
	1R	5R	10R	4,5V	5V	55V	10V	420A	5VT	10VT	
Order Code	1R	5R	10R	4,5V	5V	55V	10V	420A	5VT	10VT	
Output	1 kΩ	5 kΩ	10 kΩ	0.5...4.5 V	0...5 V	-5...+5 V	0...10 V	4...20 mA	0...5 V	0...10 V	
Supply	max. 30 V			8...30 VDC			12...30 VDC	12...30 VDC ²⁾	8...35 VDC		
Recommended cursor current	<1 μA							-			
Current consumption max.	-			max. 25 mA (no load)				-			
Power consumption max.				-				max. 200 mW			
Output current	-			max. 10 mA, min. load 10 kΩ				max. 50 mA in case of error ³⁾		max. 10 mA, min. load 1 kΩ	
Dynamics	-			<3 ms from 0...100 % and 100...0 %				<1 ms from 0...100 % and 100...0 %		1 ms	
Resolution	theoretically unlimited, limited by the noise									1 mV	
Noise	depends on the quality of the power supply			0.5 mV _{eff}				1.6 μA _{eff}		2 mV _{eff}	
Inverse-polarity protection	-			yes				-		-	
Short-circuit proof	-			yes				-		yes	
Operating temperature	-20...+85 °C / optional: -40...+85 °C or -20...+120 °C			-20...+85 °C / optional: -40...+85 °C							
Temperature coefficient	±0.0025 %/K			0.0037 %/K				0.0079 %/K		0.0016 %/K	
EMC	-			according to EN 61326-1:2013							
Circuit											

¹⁾ Galvanically isolated

²⁾ Load: 250 Ω (max. 500 Ω)

³⁾ Load max. 0.5 kΩ

MFL = multi-functional line

TECHNICAL DATA DIGITAL OUTPUT INCREMENTAL

Measurement range ¹⁾	[mm]	3000	4000	5000
Linearity	[%]	±0.05		
Improved linearity (optional)	[%]	±0.02 (only in combination with resolution 6.3 pulses/mm, or higher)		
Resolution ¹⁾	[pulses/mm]	0.3 / 3.1 / 6.3 / 15.7 (the resolution can be raised by the factor 4 using quadruple edge detection)		
Z-pulse distance	[mm]	317.68		
Sensor element		Incremental-Encoder with optical code disk		
Output signal		A, B and Z pulse (plus inverted pulses /A, /B and /Z)		
Connection		connector output M12 radial or cable output radial (PVC cable)		
Protection class		IP65, optional IP67		
Humidity		max. 90 % relative, no condensation		
Operating temperature	[°C]	-20...+85		
Mechanical data		extraction force, max. velocity and max. acceleration see „Mechanical Data“		
Housing		aluminium, anodised, spring case PA6		
Draw wire		stainless steel V2A Ø 0.5 mm		
Weight	[g]	1300 to 1600, depending on the measurement range		

¹⁾ others on request

ELECTRICAL DATA DIGITAL OUTPUT INCREMENTAL

Output type		Line driver L RS422 (TTL compatible)	Push Pull G (HTL)
Supply +V	[VDC]	5 ±5 %	10...30
Current consumption (no load)	[mA]	max. 90 (typical 40)	max. 100 (typical 50)
Load / channel	[mA]		max. ±20
Pulse frequency	[kHz]		max. 300
Signal level high	[V]	min. 2.5	min. +V -1
Signal level low	[V]		max. 0.5

Recommended circuit

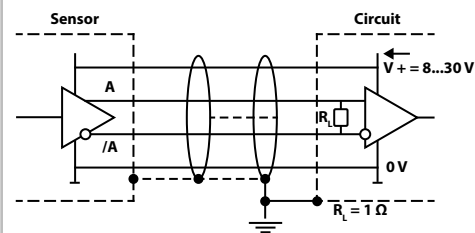
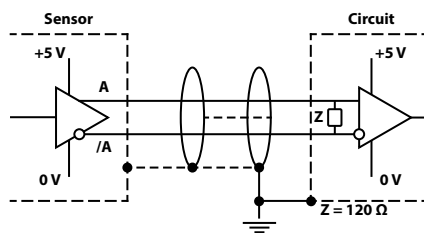

OUTPUT SIGNAL DIGITAL OUTPUT INCREMENTAL

Output signal

Pulses A and B are 90° phase-delayed (detection of direction). The Z-Pulse is emitted once per turn. The Z-Pulse distance is 317.68 mm (= circumference of the rope drum) and can be used as a reference mark.

(The diagram shows the signal without inverted signals; time line for return of rope.)

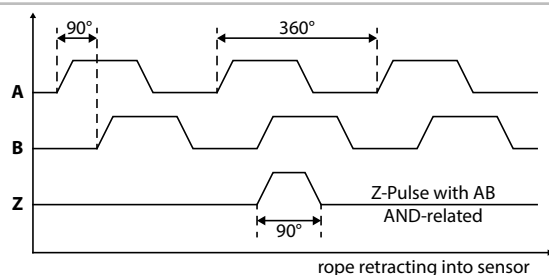

TECHNICAL DATA DIGITAL OUTPUT ABSOLUTE CAN_{OPEN} (WCAN)

Measurement range	[mm]	3000	4000	5000
Linearity	[%]	±0.1		
Improved linearity (optional)	[%]	±0.05		
Resolution		0.002 % of the measurement range		
Sensor element		Potentiometer		
Connection		connector output M12 axial/radial or cable output axial (TPE cable)		
Protection class		IP65, optional IP67		
Humidity		max. 90 % relative, no condensation		
Operating temperature	[°C]	-20...+85 / optional: -40...+85		
Mechanical data		extraction force, max. velocity and max. acceleration see „Mechanical Data“		
Housing		aluminium, anodised, spring case PA6		
Draw wire		stainless steel V2A Ø 0.5 mm		
Weight	[g]	1300 to 1600, depending on the measurement range		

ELECTRICAL DATA DIGITAL OUTPUT ABSOLUTE CAN_{OPEN} (WCAN)

Link to the manual		CANopen (WCAN)
CAN specification		Full CAN 2.0B (ISO11898)
Communication profile		CANopen CiA 301 V 4.2.0
Device profile		Encoder, absolute linear; CiA 406 V 3.2.0
Error control		Producer Heartbeat, Emergency Message, Node Guarding
Node ID		Default: 7, configurable via SDO
PDO		1 x TPDO, static mapping
PDO Modes		Event-triggered, Time-triggered, Sync-cyclic, Sync-acyclic
Transmission rate		1 Mbps, 800, 500, 250, 125, 50, 20 kbps configurable via SDO
Integrated Bus termination resistor		120 Ω, connectible via SDO
Bus, galvanic separation		No
Supply	[VDC]	8...30
Current consumption		10 mA typical at 24 V, 20 mA typical at 12 V
Measurement rate		1 kHz with 16-bit resolution
Electrical protection		inverse polarity protection
Temperature coefficient	[%/K]	0.0014
EMC		DIN EN61326-1:2013, conformity with directive 2014/30/EU

TECHNICAL DATA DIGITAL OUTPUT ABSOLUTE

Type (Link to the encoder data sheet)		SSI	CANopen (CAN)	Profibus-DP	EtherCAT	Profinet
Link to the manual / file		-	Manual / EDS	Manual / GSD	Manual / XML	Manual / GSDMI
Measurement range	[mm]	3000 / 4000 / 5000				
Linearity	[%]	±0.05				
Resolution scalable (via software)		no	yes			
Resolution standard	[pulses/mm] [bit]	12.89 12	25.79 13			
Resolution max.	[pulses/mm] [bit]	- -	206.3 16			
Sensor element	Multiturn-Absolute-Encoder with optical code disk					
Connection	see order code					
Supply	[VDC]	10...30 (reverse polarity protection of the power supply)				
Current consumption (at 24 VDC, no load)	[mA]	max. 50	max. 100	max. 120	max. 200	
Protection class	IP65, optional IP67					
Humidity	max. 90 % relative, no condensation					
Operating temperature	[°C]	-20...+85				
Mechanical data	extraction force, maximum velocity and maximum acceleration see „Mechanical Data“					
Housing	aluminium, anodised, spring case PA6					
Draw wire	stainless steel V2A Ø 0.5 mm					
Weight	[g]	approx. 1600				

ELECTRICAL DATA DIGITAL OUTPUT ABSOLUTE

Parameters of the SSI interface (8.5863.122X.G222)

Code	Gray
Output driver	RS485 Transceiver-Type
Permissible load / channel	max. ±20 mA
Signal level	HIGH: typical 3.8 V LOW: with $I_{load} = 20$ mA typical 1.3 V
Resolution	12 bit
SSI clock rate	ST-resolution: 50 kHz...2 MHz
Monoflop time	≤15 µs
Data refresh rate	≤1 µs
Status and Parity bit	on request

Parameters of the EtherCAT interface (8.5868.12B2.B212)

Code	Binary
Protocol	EtherNet / EtherCAT
Modes	Freerun, Distributed Clock
Diagnostic LED red	LED is ON with the following fault conditions: Sensor error (internal code or LED error), low voltage, over-temperature
Run LED green	LED is ON with the following conditions: Preop-, Safeop and Op-State (EtherCAT Status machine)
2 x Link LEDs yellow	LED is ON with the following conditions (Port IN and Port OUT): Link detected

Parameters of the Profinet interface (8.5868.12C2.C212)

Code	Binary
Protocol	PROFINET 10
LED Link1/Link2	green = active link / yellow = data transfer
Ezturn Software for Profinet (supplied with the encoder)	<ul style="list-style-type: none"> • Monitoring of cyclic data (e.g. position, speed) • Monitoring of acyclic data (e.g. IMO, electronic name plate, encoder parameters, warnings and error messages, preset) • Setting of preset values • Firmware updates via the bus

Parameters of the CANopen interface (CAN) (8.5868.122X.2122)

Code	Binary
Interface	CAN High-Speed acc. to ISO 11898, Basic- and Full-CAN, CAN Specification 2.0 B
Protocol	CANopen profile DS406 V3.2 with manufacturer-specific add-ons
Baud rate	10...1000 kbit/s (can be set via DIP switches or software)
Node address	1...127 (can be set via rotary switches or software)
Termination	can be set via DIP switches or software
SET Button (Option)	Zero or defined value option
LED	LED is ON with the following fault conditions: Sensor error (internal code or LED error) too low voltage, over-temperature

Parameters of the Profibus DP interface (8.5868.123X.3112)

Code	Binary
Interface	Profibus DP 2.0 Standard (DIN 19245 Part 3), RS485 Driver galvanically isolated
Protocol	Profibus Encoder Profile V1.1 Class1 and Class2 with manufacturer-specific add-ons
Baud rate	maximum 12 Mbit/s
Device address	1...127 (set by rotary switches)
Termination switchable	set by DIP switches
SET Button (Option)	Zero or defined value option
LED	LED is ON with the following fault conditions: Sensor error, Profibus error

MECHANICAL DATA

Measurement range [mm]	Extraction force F_{min} [N]	Extraction force F_{max} [N]	Velocity V_{max} [m/s] ¹⁾	Acceleration a_{max} [m/s ²] ¹⁾
3000	8	10	10	140
4000	8	11	10	140
5000	8	11.6	10	140

¹⁾ reduced to 80 % with option IP67

TECHNICAL DRAWING ANALOG OUTPUT AND DIGITAL OUTPUT WCAN

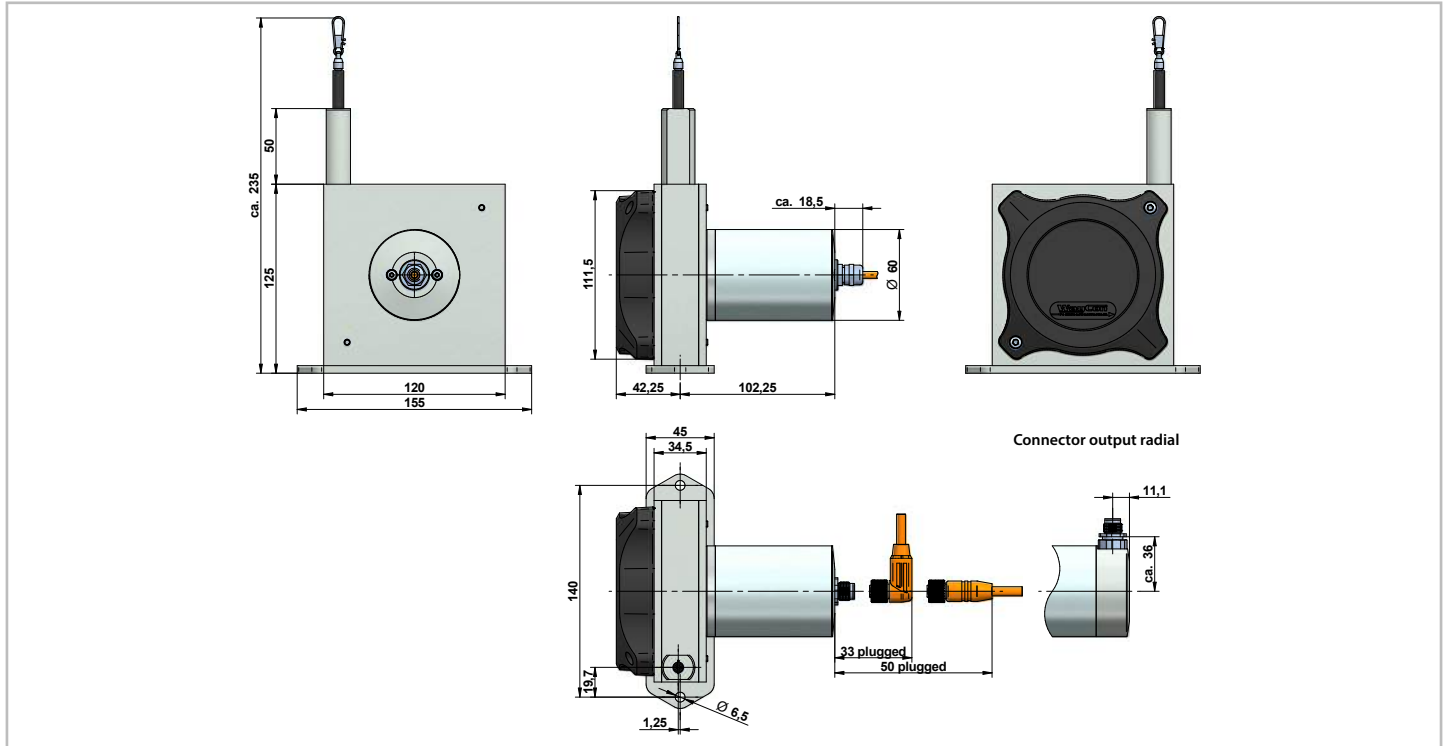

TECHNICAL DRAWING DIGITAL OUTPUT INCREMENTAL

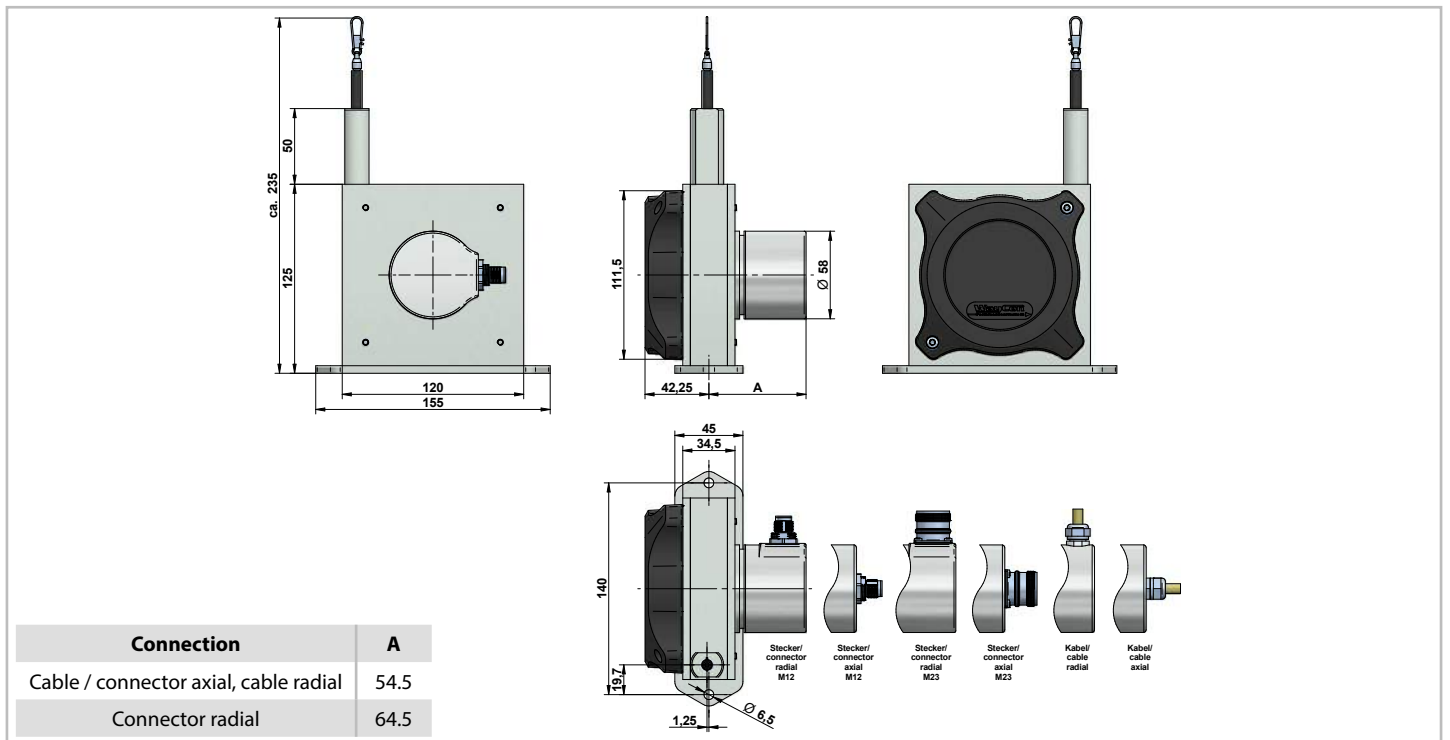

TECHNICAL DRAWING DIGITAL OUTPUT ABSOLUTE

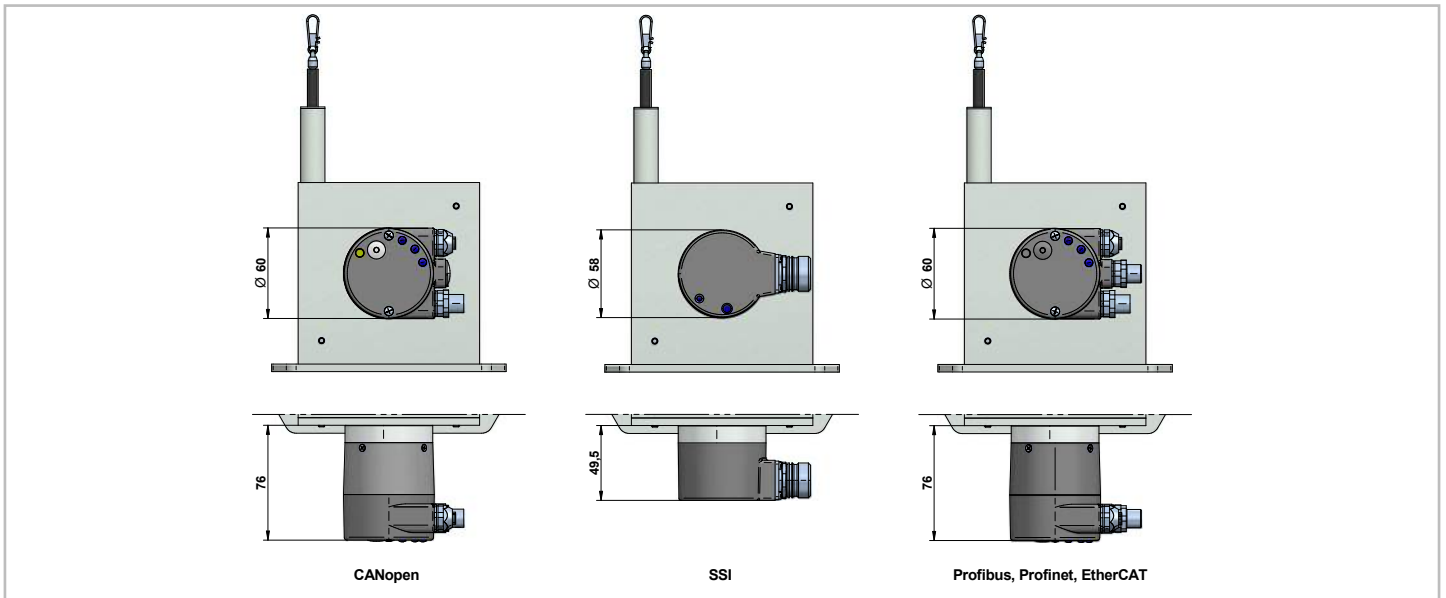

TECHNICAL DRAWING OPTIONS CHANGED ROPE OUTLET AND CABLE OUTPUT

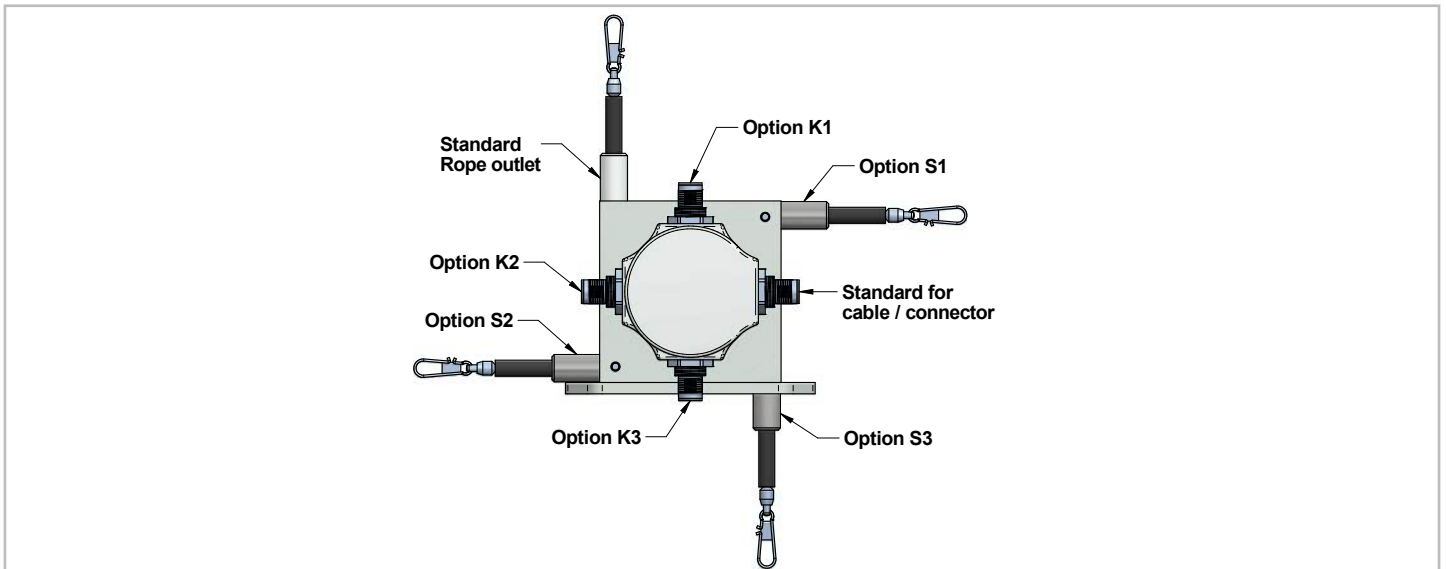

Mounting: standard rope outlet, rope outlet sideways top (S1)

The sensor is usually installed by using the regular mounting plate (see technical drawing above). By disassembling the mounting plate, there are 2 x M4 threads in the sensor housing for alternative installation. Please note that the fastening screws must not be threaded deeper than 5 mm into the sensor housing.

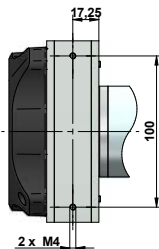

Mounting: rope outlet sideways bottom (S2), rope outlet bottom (S3)

Sensors with option rope outlet S2 and S3 have a modified base plate:

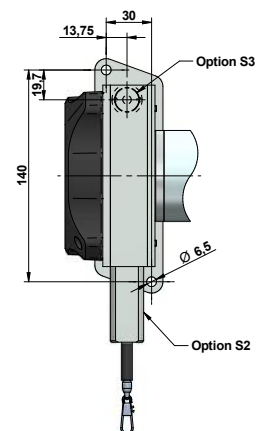

OPTIONS

Option	Order code	Description
Changed cable or connector orientation (NOT with analog output; drawing see page 7)	K1, K2, K3	Rope outlet points upwards: Standard: sideways, opposite to the rope outlet K1: at the top K2: sideways, same side as the rope outlet K3: at the bottom
Improved linearity	L02, L05	Improved linearity 0.02 % (L02) or 0.05 % (L05)
Inverted output signal (analog output only)	IN	The analog signal of the sensor is increasing by extracting the rope (standard). Option IN inverts the signal, i.e. the signal of the sensor declines by extracting the rope.
Changed rope outlet (see drawing on page 7)	S1, S2, S3	Standard: rope outlet at the top S1: rope outlet sideways at the top S2: rope outlet sideways at the bottom (modified mounting plate, see page 7) S3: rope outlet on the bottom (modified mounting plate, see page 7)
Synthetic wire rope	COR	Synthetic wire rope, made out of abrasion resistant and enhanced Coramid. We recommend COR at stable temperatures due to the coefficient of expansion.
Rope fixation by M4 thread	M4	Optional, pivoted rope fixation with screw thread M4, length 22 mm. Ideal for attachment to through holes or thread holes M4.
Rope fixation by eyelet	RI	The end of the wire rope is equipped with an eyelet instead of a rope clip. Inside diameter 20 mm
Rope fixation with cylindrical pin and M6 through bore	ZH, ZR	ZH: cylindrical pin with M6 through bore ZR: cylindrical pin with M6 through bore and carbine ring
Protection class IP67	IP67	Use option IP67, if the sensor will operate in a humid environment. Note that with this option there may occur a light hysteresis in the output signal due to the special sealing. The max. acceleration and displacement speed are reduced to 80 % of the specified value.
Corrosion protection	CP	Includes a V4A wire rope, stainless steel bearings and option M4. The sensors rope drum gets HARTCOAT® coated. This coating is a hard-anodic oxidation that protects the sensor from corrosion by aggressive media (e. g. sea water) with a hard ceramics-like layer.
Increased corrosion protection (analog output only)	ICP	Components of the housing and the rope drum get HARTCOAT® coated. Includes the options CP, IP67 and M4.
Increased temperature range High (potentiometer output only)	H120	Sensors with potentiometer output and cable output can be operated from -20 to +120 °C when this option is used.
Increased temperature range Low (analog output only)	T40	Special components and a low temperature grease make a working temperature down to -40 °C (up to +85 °C) possible.
TEDS connector (in combination with analog and cable output only; more information about TEDS)	TD, TDP, TDPS	TD: Assembling TDP: Assembling + programming TDPS: Assembling + programming + 35 measurement points

ACCESSORIES

Deflection pulley - UR2

The rope must be extracted from the sensor vertically. The maximum variation from the vertical is 3°. A deflection pulley allows a change in the direction of the wire rope. Several pulleys may be used. The rope clip must not be guided over the deflection pulley. Suitable for standard wire rope diameter 0.5 mm.

Material foot: anodised aluminium
 Material rope wheel: POM-C
 Mounting: by 2 hexagon socket or countersunk screws M6, vertical or horizontal mounting possible. Ball bearings: with special low temperature grease and RS-sealing.
 Temperature: -40...+80 °C

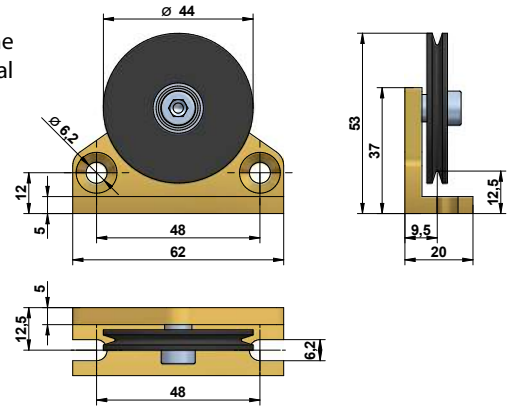
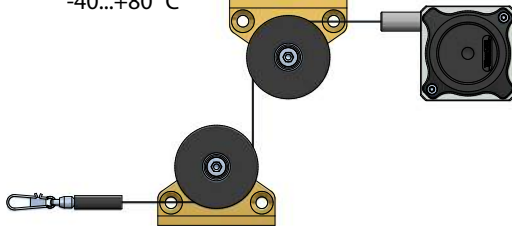

Rope extension - SV

For bridging a greater distance between the measuring target and the sensor a rope extension can be applied. The rope clip must not be guided over the deflection pulley.

Please specify the length needed in your order (XXXX). The minimum length is 150 mm:

- SV1-XXXX: rope extension (150...4995 mm)
- SV2-XXXX: rope extension (5000...19995 mm)
- SV3-XXXX: rope extension (20000...40000 mm)

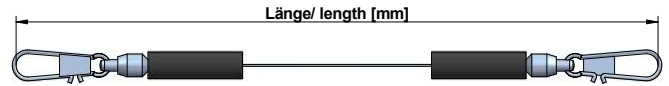

Magnetic clamp - MGG2

Use the magnetic clamp to quickly attach the rope to metallic objects without any assembly time. A rubber coating provides gentle contact (e. g. on varnished surfaces) and prevents from slipping due to vibration. The magnet consists of a neodym core for an increased adhesive force of 100 N. The hook makes it easy to attach the rope clip.

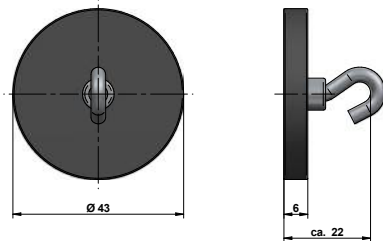

Rope cleaner - RCS

Use the RCS rope cleaner to remove dirt from the measuring rope of the sensor. Please note that the maximum measuring range of the sensor is reduced by 29 mm and that the RCS is not compatible with the option RI.

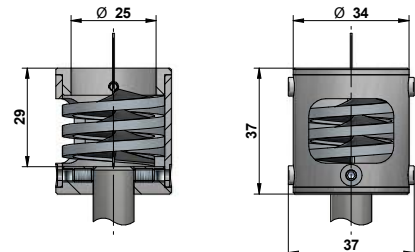

ORDER CODE ANALOG OUTPUT

SX120 - [] - [] - [] - []

Measurement range MR [mm]	
3000 / 4000 / 5000	

Output signal		
Potentiometer	1 kΩ	1R
Potentiometer	5 kΩ	5R
Potentiometer	10 kΩ	10R
Voltage	0.5...4.5 V	4,5V
Voltage	0...5 V	5V
Voltage	-5...+5 V	55V
Voltage	0...10 V	10V
Voltage	0...5 V (teachable)	5VT
Voltage	0...10 V (teachable)	10VT
Current	4...20 mA	420A

Connection	
Connector output M12, axial, 4 poles	SA12
Connector output M12, radial, 4 poles	SR12
Cable output, axial, 2 m, 4 poles	KA02
Cable output, axial, 5 m, 4 poles	KA05
Cable output, axial, 10 m, 4 poles ¹⁾	KA10

Version	
Standard	-
Sensor with options	O

¹⁾ larger lengths on request

²⁾ for more information about TEDS connectors see [here](#)

Bold text: standard with shorter lead time

Option	Description (see page 8)
L05	Improved linearity ±0.05 %
IN	Inverted output signal
S1	Rope outlet sideways top
S2	Rope outlet sideways bottom
S3	Rope outlet bottom
COR	Synthetic wire rope (Coramid)
M4	Rope fixation M4
RI	Rope fixation eyelet
ZH	Cylindrical pin
ZR	Cylindrical pin with carbine ring
IP67	Protection class IP67
CP	Corrosion protection
ICP	Increased corrosion protection
H120	Increased temperature range -20...+120 °C
T40	Increased temperature range -40...+85 °C
TD	TEDS: assembling ²⁾
TDP	TEDS: assembling + programming ²⁾
TDPS	TEDS: assembling + programming + 35 measurement points ²⁾

Option	Not combinable with
L05	5R, 10R
COR	H120
M4	CP, ICP
RI	CP, ICP
ZH	CP, ICP
ZR	CP, ICP
IP67	H120, ICP
CP	M4, RI, ZH, ZR, ICP
ICP	M4, RI, ZH, ZR, IP67, CP
H120	4,5V, 5V, 55V, 10V, 5VT, 10VT, 420A, SA12, SR12, COR, IP67, CP, ICP, T40, TD, TDP, TDPS
T40	H120
TD	1R, 5R, 10R, SA12, SR12, H120, TDP, TDPS
TDP	1R, 5R, 10R, SA12, SR12, H120, TD, TDPS
TDPS	1R, 5R, 10R, SA12, SR12, H120, TD, TDP

ORDER CODE DIGITAL OUTPUT INCREMENTAL

SX120 - - - - -

Measurement range MR [mm] 3000 / 4000 / 5000	
Resolution [Pulses/mm] 0.3 / 3.1 / 6.3 / 25	
Output signal Line driver RS422 (TTL) Push-Pull (HTL)	L G
Connection Connector output M23, radial, 12 pins Connector output M23, axial, 12 pins Connector output M12, radial, 8 pins Connector output M12, axial, 8 pins Cable output, radial, 2 m ¹⁾ Cable output, radial, 5 m ¹⁾ Cable output, radial, 10 m ^{1), 2)} Cable output, axial, 2 m ¹⁾ Cable output, axial, 5 m ¹⁾ Cable output, axial, 10 m ^{1), 2)}	SR23 SA23 SR12 SA12 KR02 KR05 KR10 KA02 KA05 KA10
Version Standard Sensor with options	- O

Option	Description (see page 8)
K1	Cable/connector orientation top
K2	Cable/connector orientation left
K3	Cable/connector orientation bottom
L02	Improved linearity ±0.02 %
S1	Rope outlet sideways top
S2	Rope outlet sideways bottom
S3	Rope outlet bottom
COR	Synthetic wire rope (Coramid)
M4	Rope fixation M4 thread
RI	Rope fixation eyelet
ZH	Cylindrical pin
ZR	Cylindrical pin with carbine ring
IP67	Protection class IP67
CP	Corrosion protection

Option	Not combinable with
L02	Resolution 0.3/3.1
M4	CP
RI	CP
ZH	CP
ZR	CP
CP	M4, RI, ZH, ZR

¹⁾ Line driver: 10 poles / Push-Pull: 8 poles

²⁾ larger lengths on request

Bold text: standard with shorter lead time

ORDER CODE DIGITAL OUTPUT ABSOLUTE CAN_{OPEN} (WCAN)

SX120 - - - -

Measurement range MR [mm] 3000 / 4000 / 5000	
Output signal CANopen	WCAN
Connection ²⁾ Connector output M12, axial, 5 poles Connector output M12, radial, 5 poles Cable output, axial, 2 m, 5 poles Cable output, axial, 5 m, 5 poles Cable output, axial, 10 m, 5 poles ¹⁾	SA12 SR12 KA02 KA05 KA10
Version Standard Sensor with options	- O

Option	Description (see page 8)
L05	Improved linearity ±0.05 %
S1	Rope outlet sideways top
S2	Rope outlet sideways bottom
S3	Rope outlet bottom
COR	Synthetic wire rope (Coramid)
M4	Rope fixation M4
RI	Rope fixation eyelet
ZH	Cylindrical pin
ZR	Cylindrical pin with carbine ring
IP67	Protection class IP67
CP	Corrosion protection
ICP	Increased corrosion protection
T40	Increased temperature range -40...+85 °C

Option	Not combinable with
M4	CP, ICP
RI	CP, ICP
ZH	CP, ICP
ZR	CP, ICP
IP67	ICP
CP	M4, RI, ZH, ZR, ICP
ICP	M4, RI, ZH, ZR, IP67, CP

¹⁾ larger lengths on request

ORDER CODE DIGITAL OUTPUT ABSOLUTE

SX120 - - - -

Measurement range MR [mm] 3000 / 4000 / 5000	
Output signal SSI CANopen Profibus DP EtherCAT Profinet	SSI CAN PRO CAT NET
Connection Connector M12, radial, 8 pins (SSI) Connector M23, radial, 12 pins (SSI) Cable output, radial, 1 m, PVC (SSI) Cable output, radial, 5 m, PVC (SSI) Cable gland, radial (CAN, PRO) ¹⁾ Connector 2 x M12, radial, 5 pin (CAN) ¹⁾ Connector 3 x M12, radial, 5 pin (PRO) ¹⁾ Connector 3 x M12, radial, 4 pin (CAT, NET) ¹⁾	SR12 SR23 KR01 KR05 KVBH SR12 SR12 SR12
Version Standard Sensor with options	- O

Option	Description (see page 8)
K1	Cable/connector orientation top
K2	Cable/connector orientation left
K3	Cable/connector orientation bottom
S1	Rope outlet sideways top
S2	Rope outlet sideways bottom
S3	Rope outlet bottom
COR	Synthetic wire rope (Coramid)
M4	Rope fixation M4 thread
RI	Rope fixation eyelet
ZH	Cylindrical pin
ZR	Cylindrical pin with carbine ring
IP67	Protection class IP67
CP	Corrosion protection

Option	Not combinable with
M4	CP
RI	CP
ZH	CP
ZR	CP
CP	M4, RI, ZH, ZR

¹⁾ removable bus terminal cover

GENERAL ACCESSORIES

UR2	deflection pulley (for rope diameter 0.5 mm)
MGG2	magnetic clamp
RCS-SX120 ¹⁾	rope cleaner

SV1-XXXX	rope extension (150 mm up to 4995 mm)
SV2-XXXX	rope extension (5000 mm up to 19995 mm)
SV3-XXXX	rope extension (20000 mm up to 40000 mm)

¹⁾ please note that the maximum measuring range is reduced by 29 mm when using the rope cleaner. The RCS is not compatible with the option RI.

ACCESSORIES ANALOG OUTPUT

Cable with connector (female) M12, 4 poles, shielded, IP67

K4P2M-S-M12	2 m, straight connector
K4P5M-S-M12	5 m, straight connector
K4P10M-S-M12	10 m, straight connector
K4P2M-SW-M12	2 m, angular connector
K4P5M-SW-M12	5 m, angular connector
K4P10M-SW-M12	10 m, angular connector

Mating connector (female) M12, 4 poles, for self assembly

D4-G-M12-S	straight connector
D4-W-M12-S	angular connector

Digital displays for sensors with analog output, 2 channel

WAY-AX-S	touch screen, supply: 18...30 VDC
WAY-AX-AC	touch screen, supply: 115...230 VAC

For more information and options please refer to the [WAY-AX data sheet](#).

ACCESSORIES DIGITAL OUTPUT INCREMENTAL

Cable with connector (female) M12, 8 poles, shielded, IP67

K8P2M-S-M12	2 m, straight connector
K8P5M-S-M12	5 m, straight connector
K8P10M-S-M12	10 m, straight connector
K8P2M-SW-M12	2 m, angular connector
K8P5M-SW-M12	5 m, angular connector
K8P10M-SW-M12	10 m, angular connector

Cable with connector (female) M23, 12 poles, shielded, IP67

K12P2M-S-M23	2 m, straight connector
K12P5M-S-M23	5 m, straight connector
K12P10M-S-M23	10 m, straight connector

Mating connector (female) M12, 8 poles, for self assembly

D8-G-M12-S	straight connector
D8-W-M12-S	angular connector

Mating connector (female) M23, 12 poles, for self assembly

CON012-S	straight connector, metal housing
----------	-----------------------------------

Digital displays for sensors with HTL output, 2 channel

WAY-DX-S	touch screen, supply: 18...30 VDC
WAY-DX-AC	touch screen, supply: 115...230 VAC

For more information and options please refer to the [WAY-DX data sheet](#).

Digital displays for sensors with HTL or TTL output, 2 channel

WAY-DXM-S	touch screen, supply: 18...30 VDC
WAY-DXM-AC	touch screen, supply: 115...230 VAC

For more information and options please refer to the [WAY-DXM data sheet](#).

ACCESSORIES DIGITAL OUTPUT ABSOLUTE CAN_{OPEN} (WCAN)

Cable with connector (female) M12, 5 poles, shielded, IP67

K5P2M-S-M12	2 m, straight connector
K5P2M-SW-M12	2 m, angular connector

ACCESSORIES DIGITAL OUTPUT ABSOLUTE SSI

Cable with connector (female) M12, 8 poles, shielded, IP67

K8P2M-S-M12	2 m, straight connector
K8P5M-S-M12	5 m, straight connector
K8P10M-S-M12	10 m, straight connector
K8P15M-S-M12	15 m, straight connector

Mating connector (female) M12, 8 poles, for self assembly

D8-G-M12-S	straight connector
D8-W-M12-S	angular connector

Digital displays for sensors with SSI output, 2 channel

WAY-SX-S	touch screen, supply: 18...30 VDC
WAY-SX-AC	touch screen, supply: 115...230 VAC

For more information and options please refer to the [WAY-SX data sheet](#).

Cable with connector (female) M23, 12 poles, shielded, IP67

K12P2M-S-M23	2 m, straight connector
K12P5M-S-M23	5 m, straight connector
K12P10M-S-M23	10 m, straight connector
K12P15M-S-M23	15 m, straight connector

Mating connector (female) M23, 12 poles, for self assembly

CON012-S	straight connector, metal housing
----------	-----------------------------------

ACCESSORIES DIGITAL OUTPUT ABSOLUTE CAN_{OPEN} (CAN)

Cable with connector M12, 5 poles, shielded, IP67

K5P2M-B-M12-CAN	2 m, female connector to open ends
K5P2M-SB-M12-CAN	2 m, female connector to male connector
K5P2M-S-M12-CAN	2 m, male connector to open ends

ACCESSORIES DIGITAL OUTPUT ABSOLUTE PROFIBUS

Cable with connector M12, 5 poles, shielded, IP67

K5P2M-B-M12-PROF	2 m, female connector to open ends
K5P2M-SB-M12-PROF	2 m, female connector to male connector
K5P2M-S-M12-PROF	2 m, male connector to open ends

Other

M12-PROF-AW	termination resistor
-------------	----------------------

ACCESSORIES DIGITAL OUTPUT ABSOLUTE ETHERCAT AND PROFINET

Cable with connector (male) M12, 4 poles, shielded, IP67

K4P2M-S-M12-CAT	2 m, straight connector
K4P5M-S-M12-CAT	5 m, straight connector
K4P10M-S-M12-CAT	10 m, straight connector

Cable with connector M12, 4 poles, shielded, IP67

K4P2M-SS-M12-CAT	2 m, male connector to male connector
K4P5M-SS-M12-CAT	5 m, male connector to male connector
K4P10M-SS-M12-CAT	10 m, male connector to male connector

Please note, that an additional cable is required for the power supply. Appropriate cables can be chosen from the list of the „[Accessories Analog Output](#)“.

Subject to change without prior notice.

WayCon Positionsmesstechnik GmbH

Email: info@waycon.de

Internet: www.waycon.biz

WayCon

Positionsmesstechnik

Headquarters Munich

Siemensstr. 5

85521 Ottobrunn

Tel. +49 (0)89 67 97 13-0

Office Cologne

Auf der Pehle 1

50321 Brühl

Tel. +49 (0)89 67 97 13-100